



**OFFICIAL
CONVENTION
RULES
REVISED
AUGUST, 2009**

**LADS
TO
LEADERS
LEADERETTES**

**Rules Book Changes
& New Events**

The Lads to Leaders & Leaderettes Official Convention Rules provide fairness and consistency in convention events. They are in no way meant to take away from the autonomy of the local elderships to set forth the focus and direction of the local group.

5280 West Alabama Christian Drive
Montgomery, AL 36109
Phone: (334)215-0251
Fax: (334)215-0856
E-Mail: ladsoffice@lads-to-leaders.org
Website: www.lads-to-leaders.org
© 2009, Lads to Leaders & Leaderettes

Are You A Winner?

- ❖ Every student who sets worthy goals is a winner.
- ❖ Every student who starts excelling for the Lord is a winner.
- ❖ Every student who studies the Bible is a winner.
- ❖ Every student who memorizes Scripture is a winner.
- ❖ Every student who learns the importance of serving others is a winner.
- ❖ Every student who becomes a Self Starter is a winner.
- ❖ Every student who stretches beyond their comfort zone is a winner.
- ❖ Every student who becomes "Firmly Grounded" is a winner.

~ Roy Johnson
Executive Director

“Competition clears my mind,
fuels my energy,
converts my apathy,
strengthens my determination,
makes me whole . . .

But I must always remember
that opponents are not enemies,
games are for enjoyment,
and winning is not always
equivalent to success.

When competition becomes obsession...
I have lost perspective
on the most important
thing of all – life!”

Jim Ponders, *Teenage Christian*,
September 1989 (Used with permission)

Honesty and Integrity

Approach all events and activities with the proper attitude.

Do your best.

Do not look for ways to stretch
or bend the rules. Your honesty and
integrity are more valuable
than silver and gold.

(Proverbs 22:1)

Important Information for Group Leaders

We want to recognize every participant who has worked hard and earned a particular award. Make sure they are registered for the correct events.

Things to do before the registration deadline.

- Collect verification forms and confirm in the registration system that the participant has earned the award. Forms do NOT need to be mailed to the National Service Center. If a participant dropped out of an event or will not be able to complete the work, deregister them from that particular event before registration closes. When registration closes, trophies, medals and certificates are ordered and names are printed on lists in the program.
- We count on "YOU", the group leader, to use the honor system. It cheapens the work of others when awards are made for those who have not earned them and they are called on stage.
- Ultimately, the responsibility is yours, at the local congregation. Before registration closes, check on the progress of all participants.

After registration closes.

- After registration closes it is extremely difficult and sometimes impossible to add people to events.

In conclusion, we do not want to see a child disappointed because they did not get their award, or confused because they got one that they did not earn. Help us make this a great experience for all participants. We appreciate what you do!

Sincerely,
Roy Johnson
Executive Director

TABLE OF CONTENTS

Special Accomplishments	7
2010 Rules Changes.....	8
Ambassadors	9
Art Says It	
Competitive	11
Non-Competitive	15
Bulletin Board, Year-Round (Advanced)	17
Banner.....	18
Bartimaeus	20
Bible Bowl	21
Bible Reading, Oral	23
Bible Reading, Year-Round (Advanced)	24
Centurion of Scripture	27
Debate.....	28
GIFTS.....	32
GUARD	33
Good Samaritan	34
Jonathan Bourland Award	36
Host & Hostess	38
Junior Leader	39
Know the Books	40
Mass Media.....	42
Article/Editorial	43
Audio Presentation.....	44
Storyline	44
Video Presentation.....	45
Website	46
Music Composition.....	48
Parade of Leaders.....	50
Parade of Winners (Reading the Bible).....	51
Pearls (Study Curriculum on topics from Bible Bowl book)	52
Puppet Theater	53
Puppet Stage Diagram.....	57
Puppeteering, Year-Round (Advanced)	58
Scrapbook, Individual & Group.....	59
Scrapbook, Winners' Circle	61
Second Language	62
Song Leading	64
Song Leading, Winners' Circle.....	66
Song Leading, Year-Round (Advanced)	67
Songs of Praise.....	70
Songs of Praise, Winners' Circle.....	72
Songs of Praise, Year-Round (Advanced)	73
Speech.....	76
Speech, Winners' Circle.....	79
Speech, Year-Round (Advanced)	80
Teaching Event: About My Father's Business – Teach to Teach.....	84

2010 Rules Changes

We listened to you!

Over the past several months, we have evaluated feedback which we received from participants, group leaders and church leadership. We use these comments to continue to tweak the rules book so that it is user friendly.

We are excited to add three new events this year. The long awaited teaching event, About My Father's Business: Teach to Teach; Year-Round (Advanced) Bulletin Board and Bulletin Board (part of Art Says It: Competitive).

The teaching event is so crucial to church growth and strength. What congregation among us doesn't need trained teens and adults to teach the Bible? Bulletin Boards are also a standard in any church, but most congregations have just a few people who are trained to create these valuable teaching tools.

We have one other new event that is in the works. Mass Media PowerPoint will be coming next year. Watch for it!

Please review the Rules Book for changes. We have separated the event forms and judge evaluation forms from the rules book to make it easier to find them. Make sure you read through and do not overlook adjustments to rules for the events and event forms. An addition has been made to the list of songs for Winners' Circle Song Leading and Songs of Praise.

College students not participating in Ambassadors should be registered as adults so that they may be registered to judge events. College students registered as Ambassadors may still judge but will not be able to register for that because they will be registered as students. These college students should attend the judges meeting for the event they wish to judge.

Beginning this year, all pre-convention events that previously required verification of participants by the group leader to be mailed or emailed to the National Service Center will now be verified electronically in the registration system. The events this will affect are: Year-Round (Advanced) Speech, Year-Round (Advanced) Song Leading/Songs of Praise, Year-Round (Advanced) Puppets, Year-Round (Advanced) Bible Reading, Centurion of Scripture, Parade of Winners, Second Language, Know the Books, Good Samaritan, Teaching event: About My Father's Business: Teach to Teach, GIFTS and GUARD. Names of Junior Leader participants and Jonathan Bourland nominees will still need to be sent in as before.

May we suggest that your family, group or congregation begin this year with a fresh **start by printing and distributing a complete rules set**. This will ensure you are working within the most recent set of rules. Our improvement efforts are without an end, and we will continue to invest in our youth to ensure spiritual growth and Christian development through program refinements, such as our Junior Leader Book for K-5th grade. More great material is coming. We will keep you posted through our e-newsletter and on our website.

We encourage you to continue speaking with us. Friendly voices, especially those with concerns, are critical to program growth and support to the local congregation.

Keep an eye to the website, more to come.....

Roy Johnson

AMBASSADORS

PURPOSE

To put to use the leadership skills that college students have gained from their years of participation in Lads to Leaders & Leaderettes. To allow college students opportunity for service to congregations new to the convention experience by serving as guides for them at convention.

SELECTION PROCESS

Participation is open to young men and women who are college students and are familiar with events and procedures at convention. Participants will be assigned a congregation to assist during the convention and will need to be available for this purpose throughout the convention period.

To be selected to serve as Ambassador is an honor.

College students may be nominated in any of the following ways:

1. Students wishing to serve must notify their group leader who can register them on the Convention Registration database.
2. Congregations may suggest specific college students of outgoing personality and helpful nature. It is important that the students are not new to Lads to Leaders and Leaderettes.
3. The National Service Center may submit names from workshops and scholarship applicants. The National Service Center will refer names to the coordinator.
4. Board members and convention event coordinators may submit names to the coordinator of Ambassadors.

The coordinator will send an invitation to the college student or team leader and request a RSVP by a specific date. If no RSVP is received by the date, the name will be dropped and another student will be contacted.

GUIDELINES

A. Event Participation

1. Be available for instructional meeting by coordinator. The coordinator will have a list of frequently asked questions by new groups and ambassadors are expected to familiarize themselves with these questions and suitable answers. If an ambassador does not show up for this meeting, they will not be allowed to participate.
2. Responsibilities
 - To meet the new group when they arrive and assist throughout convention weekend.
 - To be a Tour Guide and Question and Answer person for this new group.
 - Ambassadors must be available to greet the new group upon the new group's arrival.
 - Ambassadors will assist them with the check in and assist them with finding registration areas, New Group's reception, Men's Meeting room, etc.
 - They will be expected to spend time with this new group. The coordinator will contact the Ambassadors and give them the contact information for the new group leader so that they may contact them prior to convention and exchange cell numbers and email addresses.

Important: The Ambassador must place their priority on serving their assigned group and NOT their home congregations. The new groups are very dependent on the Ambassador's dedication.

B. Dress

1. Group Leaders: Make sure your Ambassadors are dressed modestly and appropriately. It is a positive or a negative reflection on your congregation. Attire for Friday noon-Saturday: church dress, pantsuits, sport coats, etc. (no t-shirts, jeans or shorts).
2. Attire for awards ceremonies: Sunday church attire, informal or formal (**No strapless, no spaghetti straps, no low cut, no short or tight dresses**). Remember that you represent Christ and His Church. **Students are encouraged to look their best as Christian examples. Students dressed immodestly will be dismissed from their service.** While an Ambassador's presence may complement an event, it is not to be a distraction.

C. Expectations

After convention, new groups will be sent an evaluation form to rate the service provided by their Ambassador.

AWARDS

They will be given a special badge and will be recognized at the Awards Ceremony.

ART SAYS IT

Competitive

PURPOSE

To offer students an opportunity to use their talents, skills, and the tools of drawing, painting, and other art media to communicate a Biblical message related to the annual convention theme.

EVENT PARTICIPATION

- A. Art Says It is an individual event. While adult guidance is appreciated, the creation and production of the artwork must be the responsibility of the student.
- B. Participants must be in grades 3 through 12.
- C. Participants are divided into the following divisions:
Grades 3-4 Grades 5-6 Grades 7-8 Grades 9-10 Grades 11-12
- D. K-2 and Bartimaeus participants may participate in Non-Competitive Art Says It. See the Art Says It Non-Competitive section for information.
- E. Individuals may only submit one entry per category in any of these four categories:
 1. Drawing/Sketching
 2. Painting
 3. Photography
 4. Poster
 5. **Bulletin Board (Pre-convention ONLY) – Rules for this new category begin on page 13.**
- F. Refer to Art Says It Non-Competitive for other categories and options.

EVENT RULES AND GUIDELINES

Entries in each of the four categories will be judged for construction, content and creativity.

- A. **Construction (Type of Material):**
Effective Use of Materials/Media – The work should reflect that the artist gave thought and time to creating the piece. The overall quality of the piece should show workmanship, including neatness and composition.
- B. **Content (Topic of Work):**
Emphasis should be on glorifying God, serving others and imitating Christ. Artwork should adequately reflect the theme of the convention. Teaching Bulletin Boards should adequately reflect biblical truths..
- C. **Creativity (Design):**
Originality – uniqueness
Design – layout, neatness, organization
Overall Appeal – impression (this is very subjective)

GENERAL RULES FOR CONSTRUCTION, CONTENT AND CREATIVITY

- A. The actual artwork entries for Painting or Drawing/Sketching must be at least 8 1/2" x 11", but must not exceed 16" x 20". These sizes include any matting or framing. No "painting by numbers" accepted.
- B. All photo entries can be color or black and white. All photo entries must be framed and/or matted. All photo entries must be at least 4" x 6" and must not exceed 8 1/2" x 11". These sizes include any matting or framing. Digital enhancement of photographs is not allowed. Photos taken with a digital camera may be submitted, but cannot be fixed, corrected or enhanced in any way before printing. This category is photography, not computer enhancements, graphics or manipulation of photographs. We rely on your honesty and integrity.
- C. Posters should adhere to the following guidelines:

1. Posters must be based on the overall convention theme.
 2. Standard poster board must be used (22 inches by 28 inches).
 3. No copyrighted figures (such as cartoon figures) may be used, unless written permission is acquired.
 4. Collage designs may be used to decorate posters but must be able to be displayed as a poster.
- D. Titles and descriptions are not required for art entries, but may be included, if desired, to better associate the work with the annual convention theme.
 - E. **Do NOT sign your work prior to the judging. Neither the student's name nor congregation should appear on the face of the entry. This rule is in the student's best interest to ensure fairness to all.**
 - F. **Do not enter artwork which previously has been entered in a Lads to Leaders & Leaderettes Art Says It event. Only new entries are acceptable.**
 - G. A copy of the Art Says It Entry form found on our website on the Rules Book page should accompany each entry. Click the Entry Forms and Log Sheets link to access the forms.
 - H. A registration card will be used to identify each entry anonymously. This card will be supplied at the convention and will be attached to the face of the entry to be used for judging purposes. It will contain an I.D. number (assigned at the time of registration at convention), grade division, team color designation and medium.
 - I. Art must be received at the Art Says It registration desk on Friday at the scheduled time (see Convention Schedule of Events) and should remain on display until 5:00 PM on Saturday. Art registration will officially close at the scheduled time of the judges meeting (check Convention Schedule of Events). Art entries received after that time will be accepted and added to the tables for judging **ONLY AS TIME ALLOWS**. After judging begins, art will be accepted for display only.
 - J. **Groups are responsible for picking up all artwork by 5:00 PM on Saturday.**
 - K. Each entry is eligible for only one award. A student may enter only one piece of art in a category. The same piece of art cannot be judged in more than one category.

CATEGORIES

Use a **medium** listed below. Participants can submit only one entry per category, in a maximum of three different categories.

- Poster
- Painting: Oil, Tempera, Watercolor, Acrylic and Airbrush
- Drawing/Sketching: Pen/Ink, Pastel, Chalk, Crayon, Charcoal, Pencil and Colored Pencil
- Photography: Black & White or Color
- Bulletin Board (Pre-convention ONLY)

JUDGING

- A. Based on the above rules, artwork will be judged according to the official evaluation guide included in this rules book.
- B. Three to five judges (preferably with art backgrounds) will work independently to examine and score each art entry. The combined totals of all the judges will determine the winners. Each congregation must provide one qualified judge for each four art entries or portions thereof. Example: 1-4 entries, one judge; 5-8 entries, two judges, etc.
- C. Penalties
 1. Any self-identification by a participant shall be penalized three points.
 2. Entries that do not meet the size requirements previously stated shall be deducted five points.

AWARDS

First, second, and third place awards will be given in each of the grade divisions for each category. **When the numbers in a category exceeds 24 in any one grade division; finalist awards will also be given. There will be no "red/white, green/white", etc. divisions.**

Bulletin Board (Competitive)

PURPOSE

To offer students an opportunity to use their serving spirit, creativity, talents, and skills, to create bulletin boards to benefit their local congregation.

EVENT PARTICIPATION

- A. Participants are divided into the following divisions **for Bulletin Board only**:
Grades 3-4 Grades 5-6 Grades 7-9 Grades 10-12
- B. The bulletin board must be based on the current year's convention theme.
- C. Individuals may only submit one entry per category in these two categories:
 - 1. **Informative/Decorative** - This category includes most of the boards in the hallways of the church. It may provide information about missions, new programs, sign-ups, etc. This bulletin board may tell you about an event that has happened, have pictures of that event and/or explain the annual events of the congregation. Decorative can be seasonal boards that help beautify the building, have pictures, a Bible verse, or just encourage the congregation in some way.
 - 2. **Teaching** - These are usually found in a classroom and in some way teach a particular Bible lesson or Bible concept. There could be one large scene or several smaller images.

GENERAL RULES FOR CONSTRUCTION, CONTENT AND CREATIVITY

- A. Please email your high resolution (800 x 600 pixels or higher) .jpg format entries on or before the registration deadline date to **bulletinboard@lads-to-leaders.org**. Submit one before and one after photo for each bulletin board that you are entering into competition. The bulletin board should be based on the current convention theme. Please submit only one entry per email. In the body of the email, include the following information:
 - Bulletin Board Entry**
 - Category _____
 - Convention Location _____
 - Name _____
 - Group Name _____
 - Group City, State _____
 - Group Color _____
- B. All photo entries must be in color. Digital enhancement of photographs is not allowed. Photos taken with a digital camera may be submitted, but cannot be fixed, corrected or enhanced in any way before submitting, so take several photos of before and after to get the true colors and a clear picture. Please only send in one best before and one best after shot.
- C. Copyrighted figures (such as cartoon figures) may not be used, unless they are purchased for use on bulletin boards or you have approval to use them.
- D. Titles and lettering are not required on bulletin boards, but the bulletin board must clearly convey a thought.
- E. Taking one item off a bulletin board and putting another up is not acceptable. Background paper/cloth may remain the same, but the border, and all items on the bulletin board must be new to the board.
- F. Ideas may come from a bulletin board book or another source but the overall composition and scheme must be your own.
- G. Since this bulletin board is to benefit the church or classroom, a mentor/ teacher should guide the competitor toward appropriate choices and make sure the work meets a high standard. The mentor should give suggestions, but do none of the work with the exception of possibly taking the before and after pictures.
- H. Do not enter a bulletin board which has been previously entered in a Lads to Leaders & Leaderettes Bulletin Board event. Only new entries are acceptable.
- I. No entries will be returned to the participant. They become the property of Lads to Leader & Leaderettes and may be used in training, promotional productions and/or the website for instructional purposes.

JUDGING

- A. Based on the above rules, the bulletin board will be judged according to the official evaluation sheet.
- B. Three to five judges will work independently to examine and score each bulletin board entry.
- C. Entries in each of the two categories will be judged for construction, content and creativity.

1. Construction (Type of Material):

Effective Use of Materials/Media – The work should reflect that the creator gave thought and time to creating the piece. The overall quality of the piece should show workmanship, including neatness, good use of color, and composition.

2. Content (Topic of Work):

All bulletin boards should have a distinct purpose that would be beneficial to the congregation. Biblical truths will be considered. Adherence to annual convention theme is important.

3. Creativity (Design):

Originality – uniqueness (although you may use a book to get ideas, your final product should show some original ideas)

Design – layout, neatness, balance

Overall Appeal – impression (this is very subjective)

D. Penalties

Because of the unique nature of Bulletin Boards, self-identification penalties **do not apply**.

AWARDS

First, second, and third place awards will be given in each of the grade divisions for each category.

ART SAYS IT

Non-Competitive

PURPOSE

To offer participants a non-competitive environment to demonstrate their talents, skills and tools of drawing and other art media. In order to communicate a Biblical message related to the annual convention theme. Art is very subjective. This event will serve as an art gallery for the display of your work and talents.

EVENT PARTICIPATION

K-2 and Bartimaeus participants (all ages) may participate in the following categories:

1. Greeting Card
2. Collage
3. Sculpture
4. Drawing/Sketching
5. Painting
6. Photography
7. Posters

Grade 3-12 may participate in the following Art Says It Non-Competitive categories **only**:

1. Collage
2. Sculpture

- A. **Team Leaders should register individuals participating in non-competitive Art Says It events. Please note that de-registering is required when the participant elects not to participate or display their art. Event space and display tables are provided to Lads to Leaders at a premium. Help us control convention costs by reducing the over-reserving of event space and display tables.**
- B. Since these categories are non-competitive, names and other identifying information are permitted. All artwork should relate to the annual convention theme. Certificates of participation will be available on the Lads to Leaders website.
- C. Art Says It Non-Competitive is an individual event. The creation and production of the artwork must be the responsibility of the participants.

EVENT RULES AND GUIDELINES

Entries should follow the same guidelines as Art Says It Competitive for construction, content, and creativity even though they will not be judged.

- A. **Construction (Type of Material):**
Effective Use of Materials/Media – The work should reflect that the artist gave thought and time to creating the piece. The overall quality of the piece should show workmanship, including neatness and composition.
- B. **Content (Topic of Work):**
Emphasis should be on glorifying God, serving others, and imitating Christ. Artwork should adequately reflect the theme of the convention.
- C. **Creativity (Design):**
Originality – uniqueness
Design – layout, neatness, organization
Overall Appeal – impression

GENERAL RULES FOR CONSTRUCTION, CONTENT AND CREATIVITY

- A. Greeting Cards category is designed so that children could learn how to make handmade cards for individuals. Handmade cards are also part of Good Samaritan. Greeting Cards must be handmade and not computer generated. This is an activity that promotes creativity and encourages others to send greeting cards to the sick, etc.
- B. Sculpture entries are to be no larger than 24" x 24" x 24". Sculpture entries should be entirely the work of the participant. No pre-cast molds accepted.
- C. Collage should not exceed 16" x 20" including the matting or framing.
- D. All photo entries can be color or black and white. All photo entries must be framed and/or matted. All photo entries must be at least 4" x 6" and must not exceed 8 1/2" x 11". These sizes include any matting or framing. Digital enhancement of photographs is not allowed. Photos taken with a digital camera may be submitted, but cannot be fixed, corrected or enhanced in any way before printing.
- E. The actual artwork entries for Painting or Drawing/Sketching must be at least 8 1/2" x 11", but must not exceed 16" x 20". These sizes include any matting or framing.
- F. Posters should adhere to the following guidelines:
 1. Posters must be based on the overall convention theme.
 2. Standard poster board must be used (22" by 28").
 3. No copyrighted figures (such as cartoon figures) may be used, unless written permission is acquired.
 4. Collage designs may be used to decorate posters but must be able to be displayed as a poster.
- G. Titles and descriptions are not required for art entries, but may be included, if desired, to better associate the work with the annual convention theme.
- H. Art must be received at the Art Says It registration desk on Friday at the scheduled time (see Convention Schedule of Events) and should remain on display until 5:00 PM on Saturday.
- I. **Groups are responsible for picking up all artwork by 5:00 PM on Saturday.**

CATEGORIES

Participants can submit only one entry per non-competitive category.

- Collage: Textile, Fabric and any other material combined together. Collages can be attached to poster board or can contain three-dimensional images or projections.
- Greeting Card: Paper, fabric, foam, yarn, etc. Handmade artwork and design. Expressions, poems, etc., may be included but must be either student's original thought or a Biblical message. No computer-generated work is admissible.
- Sculpture: Carving, molding, or welding of any material. Materials must be formed or manipulated in some manner.
- Poster
- Painting: Oil, Tempera, Watercolor, Acrylic and Airbrush
- Drawing/Sketching: Pen/Ink, Pastel, Chalk, Crayon, Charcoal, Pencil and Colored Pencil
- Photography: Black & White or Color

YEAR-ROUND (Advanced) BULLETIN BOARD

This is a non-competitive event... one competes only with self.

PURPOSE

Participants will decorate a bulletin board at their home congregation several times during the year. Bulletin boards located in classrooms, hallways or other locations inside the church building can be decorated for the congregation.

EVENT PARTICIPATION

This is an individual event for Grades 3-College, as well as adults. Participants must have the approval of the local eldership/leadership.

EVENT RULES AND GUIDELINES

- A. Entries of all bulletin boards created must be submitted by email on or before the registration deadline to bulletinboard@lads-to-leaders.org. There should be one before and one after picture of each bulletin board to show the work. Entries must be high resolution .jpg format - at least 800 x 600 pixels. In the body of the email, include the following registration information:

Year-Round (Advanced) Bulletin Board

Name _____

Convention Location _____

Group Name _____

Group City, State _____

Group Color _____

Total Number of Bulletin Boards _____

- B. Taking one item off a bulletin board and putting another up does not count. Group leaders must guard the integrity of this event by making sure it benefits the congregation and is not just done to see how many bulletin boards can be put up and taken down again. Background paper/cloth may remain the same, but the border and all items on the bulletin board must be new to the board.
- C. There must be at least 5 items on the bulletin board, not including background or border. Examples of items that constitute one item would be: a title, a drawing, a picture, a figure, an information sheet, etc.
- D. Ideas may come from a bulletin board book or another source, but the overall composition and scheme must be your own.
- E. Since this bulletin board is to benefit the church or classroom, a mentor/teacher should guide the participant toward appropriate choices and make sure the work meets a high standard. The mentor should give suggestions but do none of the work with the exception of possibly taking the before and after pictures.
- F. Bulletin boards are to be counted from convention registration deadline to convention registration deadline, not January through December.

AWARDS

Awards will be given based on the number of bulletin boards made from convention to convention.

Bronze 4-7 Bulletin Boards

Silver 8-11 Bulletin Boards

Gold 12 or more Bulletin Boards

BANNER

PURPOSE

To encourage team organization and creativity among students in the creation of banners to be displayed at group functions, youth rallies, church, or in the community.

EVENT PARTICIPATION

Congregations may enter one or more banners.

EVENT RULES AND GUIDELINES

- A. Banners shall sum up the personality of the team. Banners are a team expression.
- B. Each team has its own unique personality, and the banner should reflect such. Unlike other events, banners do not have to reflect the annual Convention theme.
- C. Banners must be received at the Banner Registration Desk on Friday at the scheduled time (See Convention Schedule of Events). A group representative will fill out an official entry form at that time.
- D. Banners must display the Lads to Leaders & Leaderettes name or the "Flying L" logo. Banners without the name or logo will be disqualified.
- E. The local program must be identified, including the city, state, and congregation within the design of the banner. Banners that are not identified will be penalized.
- F. Maximum dimensions are 28" by 22", including foldouts, fringe, or floating objects. (This is the standard size of poster board and is convenient for transportation.) Banners may be designed in either portrait (tall) or landscape (wide) format. There is no depth restriction. The measurements exclude any rope or hanging device.
- G. Banners must be constructed to be easily moved and displayed on an easel provided by the congregation. Some hotels are able to provide easels, but please do not count on it. Be prepared in case the hotel does not have easels in its inventory.
- H. Banners must not require an electrical outlet.
- I. No copyright figures (such as cartoon figures) may be used, unless written permission is acquired.
- J. The banner must be designed and constructed solely by the students. Any assistance offered by adults must be supervisory or consultative only.
- K. Banners will be evaluated and rated based on the following:
 1. Content – best portrayal of group
 2. Creativity – originality, materials, enhancement
 3. Construction – detail, layout
- L. Banners submitted must have never been previously entered into convention competition.
- M. Banners should remain on display until 5:00 PM on Saturday. Groups are responsible for picking up their banners.
- N. Banners may be made from any one or multiple types of materials.

JUDGING

- A. In addition to the event rules above, banners will be judged according to the Convention Rules and the official Banner Judge's Sheet.
- B. Three to five judges will work independently to examine and score each banner entry. The combined totals of all the judges will determine the winners.

AWARDS

Awards for first, second and third place will be given.

JUDGES' INSTRUCTIONS FOR BANNER EVENT

1. A banner will be disqualified if it does not include the Lads to Leaders & Leaderettes name or "Flying L" logo.
2. Banners will be judged in three major categories: Content, Creativity and Construction. A maximum of 25 points may be given in each category by each judge.
3. Category definitions:
 - a. Content – best portrayal of group
 - b. Creativity – originality, materials, enhancement
 - c. Construction – detail, layout
4. Penalties
 - a. Disqualification – not including Lads to Leaders & Leaderettes name or the "Flying L" logo in the design
 - b. Incorrect size – (-10) over maximum size
 - c. Identification – (-15) not identifying the group on banner
 - d. Late entry – (-10) banners turned in after the deadline
 - e. Copyright – (-10) not providing authorization for use of copyrighted material

BARTIMAEUS

This is a non-competitive event... one competes only with self.

PURPOSE

To provide an opportunity for students and adults with special needs to give a speech, lead a song or read from the Bible in a non-competitive, friendly environment.

EVENT PARTICIPATION

Participation in Bartimaeus events is strictly voluntary and is open to anyone of any age.

EVENT RULES AND GUIDELINES

There are four different areas for Bartimaeus participation – Oral Bible Reading, Art Says It, Speech and Song Leading (males)/Songs of Praise (females). When Leaderettes Oral Bible Reading, Leaderettes Speech and Songs of Praise are taking place, only other females may be in the room. All stated rules and guidelines in the rules book for these events are in effect for the Bartimaeus events, with the exception of the following:

Oral Bible Reading

No minimum time limit – maximum time remains at 2 minutes.

Art Says It

Artwork will be placed on a table for display only in the area where all artwork is displayed.

Speech

Speeches should be no more than 3 minutes in length.

Song Leading/Songs of Praise

Either one or two verses of a song may be led.

EVALUATION

While the participants are not competing for place awards, there will be adults in the room serving as moderators. They will provide positive feedback to the participants after completion of their events.

Encouragement and applause are to be expected in the Bartimaeus events.

AWARDS

Each participant will receive a certificate at the conclusion of each event in which he/she participates. During the awards ceremony on Saturday night, all Bartimaeus participants will be recognized and presented with an award on the stage. Each participant will receive only one Bartimaeus award, regardless of the number of events in which he/she participates.

BIBLE BOWL

PURPOSE

To enable students to enhance knowledge of textual content; to develop quick reference to Bible facts and gain knowledge of Scripture; to bond through team spirit.

EVENT PARTICIPATION

- A. Any individual student in grades K-12 may prepare for and take the test to qualify for an individual award. For the Individual Test High Score **ONLY**, there will be a K-2 division.
- B. Teams may participate in the following divisions:

Grades 3-4 Grades 5-6 Grades 7-8 Grades 9-10 Grades 11-12

Criteria for teams are as follows:

1. Students may participate on only one Bible Bowl team.
 2. Team members may be boys and girls from grades K–12. However, no more than two students younger than third grade may be on one team. The youngest grade division for any team will be 3-4.
 3. Students may **not** participate below their grade, but may participate in a division above their current grade.
 4. A “team” consists of four participants – no more and no less. If there is an emergency and an alternate team member is necessary, the team leader may select any student from the congregation to fill in as long as the person is age appropriate. The student chosen does not have to be one that took the Bible Bowl test.
 5. A congregation may have any number of teams.
- C. Questions will be worded from the New King James Version. Each year, the area of study (Book or verses) to be used for the following year will be announced at the Convention. **Study materials may be ordered from the National Service Center.**

EVENT RULES AND GUIDELINES

A. Rules for Written Test

1. You do not have to be a member of a team to take the individual test, but any team that wishes to participate in the oral Bible Bowl at convention must have four team members registered as a team by the registration deadline indicated in the Convention Registration packet.
2. The written test will be made available on the Lads to Leaders website by the testing dates listed in the Convention Registration packet. Local congregations will administer the qualifying test in a controlled and monitored environment during the dates specified in the Convention Registration packet. There will be a one-hour time limit for all written tests. The written test is to be taken “closed-Bible.” Bibles, study questions and other material may NOT be used during the test. It is important that this standard be maintained in every congregation in order for this to be a fair competition. We realize that not all students may be able to complete all questions during the time allotted, but if all participants are given the same amount of time, we can have a fair comparison as we rank the top students. The test will consist of 100 multiple choice questions. The questions will be in the same format as the study questions, but they will not be taken directly from the study questions. Therefore, be sure to study the text of the selected book, not just the study questions. Local congregations should **mail the answer sheets back to their convention site’s Bible Bowl coordinator (not the National Service Center), so that the sheets will be received by the Bible Bowl deadline posted on the Lads to Leaders website** in time to be scored prior to convention.
3. Since some of the students taking the test will be young and may have trouble reading, the questions and answer choices may be read to them by an adult. However, Bible verses are not to be read along with the questions.
4. Before the tests are mailed to the coordinator, double-check to make sure that all students’ information is complete and accurate on the answer sheets. Each must include the student’s name, grade they are currently in (not the grade level of the team that they are on), color division (where applicable), and congregation name, city and state.

5. All grades will take the same test. Individual awards will be given based on the scores of the written test. Students will be compared to others in their same grade level. This is not a pass or fail grade.
6. Do not wait until after the test deadline to attempt to resolve problems such as missing test pages, copier problems, etc. Contact the National Service Center at any time to resolve problems with the test.

B. Rules for Oral Rounds

1. All teams properly registered by the published registration deadline will participate in the oral rounds at convention. The eight "finalist" teams will be determined from the team scores during the oral rounds. The finalist teams will be called by name to the stage during the awards ceremony. The three top-scoring teams will be announced and receive their awards. The remaining finalist teams will receive their awards as they exit the stage. **NOTE:** Questions for the written test and oral rounds at convention may be taken directly from the study questions, rephrased study questions or new questions.
Questions will be multiple choice and are to be answered by each team member, as follows:
 - a. A set of answer cards ("A," "B," "C," "D") will be provided for each team member. Each team member will display their answer card when called by the person reading the questions. Team members may not confer with one another.
 - b. One point will be assigned for each correct answer.
2. Teams must be ready to participate in the final rounds. If all members are not present when called, the team must participate with those who are present. Late participants will be seated promptly after they enter the room. However, a question in progress is not to be interrupted to seat late team members. An absent team member will receive a score of zero for unanswered questions. If an alternate is used, he/she must remain as part of the team throughout the oral rounds. The late student cannot take the place of the alternate when he/she arrives.
3. Grades 3-6 will answer 40 total questions. Grades 7-12 will answer 60 total questions.
4. The teams and the audience will face the reader.
5. Computer projector(s) will be used to show the questions and answer choices on a large screen. Questions will be read only one time.

JUDGING

The following adult roles are necessary to conduct the oral rounds (**NOTE: Groups must provide at least one judge per registered team**):

- A. **READER:** responsible for reading orally the questions in the final rounds; should have a strong voice and feel confident with pronunciation.
- B. **SCORE KEEPER** (one per team): responsible for recording individual responses and computing team scores; should feel comfortable with math (would be advised to bring a pocket calculator).
- C. **ROOM MONITOR:** responsible for limiting the distractions, either from individuals entering and leaving the room or from the audience. Holds everyone in place until the top three teams are determined.
- D. **ROOM LEADER:** responsible for checking the room prior to the oral rounds to ensure that all materials (dividers and answer cards) are ready; during the event will help resolve questions which may arise. Verifies team scores and completes the winner's list.
- E. **JUDGES:** are given the authority to dismiss from the room any adult, student, or audience member who chooses to participate in cheating or inappropriate behavior. **WINNING IS NOT AS IMPORTANT AS HONESTY AND INTEGRITY.**

AWARDS

- A. The top 10 scorers on the written test in each grade division receive High Scorer awards.
- B. First, second and third place group awards will be given to the winning teams, along with individual awards for members of those teams. Finalist teams not placing in the top three will be recognized and presented with finalist awards. Only active team participants will receive an award at convention. If a team with alternate members wins an award, the congregation may purchase additional awards through the National Service Center for these members after the convention.

ORAL BIBLE READING

This is a non-competitive event... one competes only with self.

PURPOSE

To emphasize the fundamental importance of Bible reading and to strengthen the foundation for public speaking. Bible reading is an important skill for young students to develop – the younger the better. Beyond the fundamental importance of reading the Bible, the skill of oral reading is also a foundation for other public speaking.

EVENT PARTICIPATION

- A. Students in kindergarten through sixth grade may participate.
- B. Students in kindergarten through second grade will not be rated.

EVENT RULES AND GUIDELINES

- A. Readings may be taken from either the Old Testament or the New Testament. Any standard translation may be used. No paraphrase Bibles may be used.
- B. The Scripture reading may not be less than one minute nor more than two minutes in length.
- C. No males will be allowed in the rooms where Leaderettes are participating in Oral Bible Reading.

JUDGING

- A. The reading of Scripture will be judged on a one-to-three basis of: **Excellent (3); Good (2); and Needs Improvement (1)**.
 - 1. Rating Sheets completed by the judges will be given to the participants.
 - 2. Ratings will be: **AAA, 14-15 points; AA, 11 to 13 points; and A, 10 points and below.**
- B. Participants will be judged on the following criteria:
 - 1. The Scripture reading may not be less than one minute nor more than two minutes in length. Students will be penalized one point for one to 30 seconds under one minute or over two minutes; two points for 31 to 60 seconds under one or over two minutes; etc.
 - 2. The reader will be judged as to neatness and appearance. "Sunday dress" is expected for this event. However, no stringent dress code has been adopted. A Lad will not be penalized for not wearing a coat. Grooming and neatness are important in appearance.
 - 3. Poise and posture while reading will be rated.
 - 4. Enunciation, voice and articulation will be rated.
 - 5. The effectiveness of the participants in the identification of the passage and translation will be rated.
 - 6. The appropriate voice volume for the room used will be rated.

AWARDS

- A. Rating sheets and certificates of participation will be given to each participant based on the above ratings.
- B. Readers below third grade will not be rated, but will receive a certificate of participation.

YEAR-ROUND (Advanced) BIBLE READING

This is a non-competitive event... one competes only with self.

PURPOSE

To promote year-round, local Bible reading in front of various audiences. To develop outstanding reading skills and through these skills, to increase opportunities to serve others.

EVENT PARTICIPATION

Grades 3-College

LEVELS OF PARTICIPATION

There are 5 levels of participation, which must be earned in sequence – one level per year. All work must be completed prior to the convention registration deadline. Students may qualify for only one award per convention year. If work is not completed, **DO NOT** register a student for this award.

A. Level I – Student Reader

Students gain experience reading the scriptures before audiences. Emphasis is on narrative readings (beginning with the start of a story and ending with the conclusion).

B. Level II – Servant Reader

Students use developed skills to serve others through reading, while building and improving the basic skills practiced as a Student Reader.

C. Level III – Skilled Reader

Students refine skills, expanding the knowledge gained at the previous levels, and develop different styles of reading for different texts.

D. Level IV – Master Reader

Master Readers are comfortable and expressive while reading any passage from the Bible. They are able to select appropriate passages for a variety of needs.

E. Level V – Accomplished Master Reader

In this level, Master Readers continue to refine their Bible reading skills as they work on their voice, enunciation, and microphone skills.

Note: Each Advanced Bible Reading level becomes more challenging. This is intentional. It is hoped that by the time a young person becomes a Master Reader, he/she will have developed into an excellent verbal handler of the Word of God. The projects are designed to be demanding but not overwhelming. We feel that the reading of God's word has been neglected, but it deserves our very best. May God bless you with the desire to excel in bringing the Word of God to the ear of man.

Entry forms may be found in the Entry Forms and Log Sheets section of the Rules Book page of our website. These forms should be completed and kept in each student's file for their records. The forms are **NOT** to be mailed to the National Service Center. Group leaders are to electronically verify each participant of this event in the registration system.

EVENT RULES AND GUIDELINES

A. Level I Student Reader

1. Student must select two narrative Bible passages. A "narrative passage" is a Bible text that starts with the beginning of a story and ends with the conclusion of that story. For example, Luke 21:1-4, John 3:1-7, or Acts

5:1-11. Much of the Old Testament is narrative (Genesis 37:3-36, 2 Samuel 23:20-23). Students must read both of the selected passages to five different audiences. An "audience" is not necessarily a crowd. An "audience" may take the form of Bible classes, worship services, nursing homes, neighbors, friends, school groups, youth groups, or grandparents.

B. Level II Servant Reader

1. Student must have already earned the Level I Student Reader.
2. Student must identify, select, and read two appropriate passages to persons who fit **at least two of the following categories**:
 - a. The Servant Reader serves as a mouthpiece for the congregation (or Ladies class) reading passages for the speaker.
 - b. The Servant Reader serves as information for small children or illiterate.
 - c. The Servant Reader serves as comfort for the sick, disabled, or bereaved.
 - d. The Servant Reader serves as peace for the fearful (lonely or shut-in).
 - e. The Servant Reader serves as eyes for the seeing impaired.
3. Student should read an entire book of the Bible to someone. The book should be a minimum of 10 chapters and read over the course of several visits or settings.
4. Student must write a one page statement describing what he/she learned from being a servant reader.

C. Level III Skilled Reader

1. Student must have already earned the Level II Servant Reader.
2. Student should practice oral readings from several different standard translations. A truly skilled Reader should be comfortable reading from an older standard translation as well as newer standard translation. Skilled Readers must be prepared to read from the standard version with which the audience is most comfortable. To fulfill this requirement, the student must complete the following:
 - a. Student and his/her chosen adult or adults must select at least 12 passages of Scripture that they will work on together. Selections should begin with simple, familiar texts (e.g. Genesis 1, Psalm 23, and Matthew 5), and continue through texts of increasing levels of difficulty (such as the genealogies, Romans 16, and Hebrews 11). Master these in one standard translation not a paraphrase.
 - b. Student will read the 12 above-mentioned texts in two other translations. Student can choose to read from older standard translations or newer standard translations, but not from a paraphrase. Seek advice from your Church leadership regarding various translations and their accuracy.
 - c. Student will select one of the 12 above passages and do a comparative word study between an older standard translation and a newer standard translation (ex. King James vs. New King James).
 - d. It is the responsibility of the student to keep a list of such things as the date, time, and place of each meeting, which Scriptures were read, which translations were used, and the advice from your church leadership. This report will be verified by the signatures of the adult(s) chosen to listen.
 - e. Student shall read through the entire Old Testament. This can be silent reading but the student should read difficult sections out loud for practice. The student can ask an adult for help with difficult pronunciations, etc.

D. Level IV Master Reader

1. The student must have already completed the Level III Skilled Reader.
2. Student must read through the entire Bible during the time he/she is attempting to earn the Master Reader award.
3. Student must record on CD an entire Old Testament book or an entire New Testament book (minimum: five chapters). These CD's should then be shared with shut-ins or those in need. A copy should also be kept by the team leader or mentor to be used a resource for your congregation. (A GREAT RESOURCE!)
4. Choose **four** out of these eight tasks to accomplish:
 - Teach someone the Gospel Plan of Salvation by reading the appropriate Bible passages to them and with them.
 - Produce audio Scripture CD's on Bible subjects (such as baptism, Lord's Supper, instrumental music, Heaven, forgiveness, drunkenness, etc.) to be used for Bible Call programs, personal evangelism, etc. Use books like Nave's Topical Bible or computer programs like Logos or Parson's Technology to find verses on these topics. (This presentation should focus on your reading ability, not necessarily your speaking ability.)

- With the advice of your minister or an elder, organize a reading to a class or the congregation, using developed skills to make the Bible come alive.
 - Plan a series of family devotionals that revolve around the reading of the Bible.
 - Organize special Scripture-reading meetings for Sunday/Wednesday night services for men or women.
 - Become a “big brother” or “big sister” to a younger Bible reading student.
 - Volunteer to train and video younger Bible readers.
 - Do a comparative reading (based on Level III: Skilled Reader) where you read from a standard translation. Making mention of other words used in other standard translations to express the point (ex. A rock vs. a stone).
5. Student must write a 2-page report on the results of his/her projects. This report will be turned in with the official certification form. Be honest. Report your successes and your failures. (We frequently learn the most from our failures.)

E. Level V Accomplished Master Reader

1. Student must have earned the Level IV Master Reader.
2. Student must read the New Testament while working on Accomplished Master Reader award.
3. Student must record on CD an entire Old Testament book or an entire New Testament book (minimum: five chapters). This must be a different book from Level Four. These CD's should then be shared with shut-ins or those in need.
4. While working on this award, the student must read a book or listen to a CD designed to help the student have a more professional voice: breathing techniques, plosives, pronunciation, enunciation, pitch, accent, resonance, volume, etc. Students should search library or electronic media to find resources available on this subject.
5. Student must listen to five public speakers/readers on radio and/or CD, then list not less than three strengths in voice qualities of each speaker/reader. He/she should also learn to recognize areas in which a speaker/reader can improve.
6. Student must write a one-page research paper on the qualities (positive and negative) of his/her own voice. Include things such as:
 - tonal qualities (nasality, breathy, resonance)
 - slurring of words and ability to pronounce certain words
 - pitch
 - accent (area of country, localisms and slang terms, etc.)
 - volume
 - pronunciation, enunciation, etc.
 - vowel and consonant problems, strengths
 - hiss in letter “s”
7. Student must learn diacritical markings enough to read them smoothly.
8. Student must have someone video tape him/her while he/she reads orally. This video can be very useful when writing the research paper on the student's own voice. The video should be shared with shut-ins and/or those in need.
9. Student must successfully complete the microphone training in the Lads to Leaders & Leaderettes Manual. An experienced and knowledgeable microphone user should train the student in this area.
10. Student must experience reading without a microphone in each of the following areas. An adult needs to stand in the farthest place in each of the areas listed below and report to the student if his/her volume (and other vocal qualities) is appropriate. The student is to practice until he/she is readily able to determine what volume is needed for what size area.
 - Small (small office or room in a home)
 - Medium (classroom size)
 - Large (Medium-sized auditorium or large fellowship hall)

AWARDS

Each level will be recognized with an award at Convention. All work must be completed prior to the convention registration deadline. Students may qualify for only one award per convention year. If work is not completed, **DO NOT** register a student for this award.

CENTURION OF SCRIPTURE

This is a non-competitive event... one competes only with self.

PURPOSE

To encourage memorization of God's word. In Acts 10, a centurion commanded 100 soldiers. The Centurion of Scripture commands 100 Scriptures by memory. This is a local, year-round event where participants memorize scriptures.

EVENT PARTICIPATION

- A. Participation in this memory work event will be open to all students and adults.
- B. Qualifying students and adults attending the Convention must register as participants.
- C. Qualifying students and adults not attending the Convention must remit the specified registration fee with their verification form. Forms are to be turned in to the team leader.
- D. All work must be completed prior to the convention registration deadline. If work is not completed, **DO NOT** register a person for this award.

EVENT RULES AND GUIDELINES

- A. A standard translation must be used.
- B. Recitation is to be verbatim.
- C. Student may select his/her own verses and may recite verses previously committed to memory. However, verses may not be used in consecutive years. For example, if a child has memorized the book of James as a second grader, he/she may memorize it again as a fourth grader.
- D. All work will be done at home during the year. The local program coordinator will appoint an adult to see that memory standards are met and verified on the form provided.
- E. When reciting Scriptures, participants must turn in a log. Each local program should keep individual records of verses memorized in a log.
- F. Log Sheets and Verification Forms can be found in the Entry Forms and Log Sheets section of the Rules Book page of our website. These are to be kept in each person's file and are **NOT** to be mailed to the National Service Center. **Group leaders are to electronically verify each participant of this event in the registration system.**

AWARDS

There is no convention participation for this event. Awards for Centurion of Scripture will be given for four (4) levels of accomplishment. Students and adults may receive an award for each new set of 100 verses completed since last convention.

Bronze: To all those who recite the 100 verses in units of ten (10 or less) per sitting.

Silver: To all those who recite 100 verses in two (2) sittings of fifty (50) verses.

Gold: To all those who recite the entire 100 verses at one sitting.

Deca: To all those memorizing 1,000 verses within 10 years or less.

DEBATE

PURPOSE

- A. To promote deeper study of Scripture as it relates to life's issues.
- B. To promote consideration of both sides of the resolution.
- C. To promote the observance of standards of procedure, which keep the discussion within bounds and ensure a fair hearing to both sides of an issue.
- D. To improve skills in extemporaneous speaking, so that participants learn to think on their feet and adapt their presentation to that of their opponent.
- E. To promote the analysis and investigation of questions that arise.
- F. To develop the following skills in critical thinking:
 - 1. Application of the principles of argumentation
 - 2. Discernment of propositions
 - 3. Discovery of issues
 - 4. Knowledge of how to study a subject
 - 5. Awareness of the proof requirements of a proposition
 - 6. Application of the tests of evidence
 - 7. Discernment between valid and fallacious reasoning
 - 8. Identification of implicit assumptions
 - 9. Recognition of the non-legal means of persuasion

EVENT PARTICIPATION

- A. Students in grades 9-12 will participate.
- B. Two debaters (two boys together or two girls together) are required to form a debate team. Individuals who need a partner may contact the debate coordinator of their convention as early as possible in the year. The debate coordinator will attempt to match up teams from such individuals, but Lads to Leaders cannot guarantee that such a match will be possible.
- C. Lads and Leaderettes will debate separately. There will be no mixed teams and no males will be allowed in the rooms where Leaderettes are debating.

EVENT RULES AND GUIDELINES

- A. The debate resolution for the following year will be announced at the National Convention. The resolution may or may not be tied to the overall convention theme.
- B. The debate resolution may be either a policy or a values resolution. In values debate, the affirmative team argues for the proposition, while the negative team challenges the proposition. In policy debate, the affirmative team argues for the adoption of the resolution as policy, while the negative team argues against its adoption. The resolution may also be a truth/error topic such as baptism.
- C. Teams: Each debate round will be between two teams of two speakers each. Each team will participate in two rounds, one on the affirmative side and in the other on the negative side.
- D. Seating: The following diagram indicates the location of principal participants in the debate.

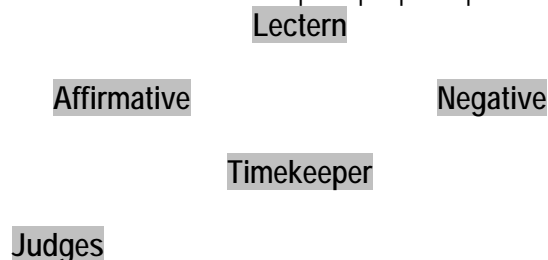

E. The following schedule is to be used (this entire arrangement represents one round):

- First affirmative constructive 5 minutes
- First negative constructive 5 minutes
- Second affirmative constructive 5 minutes
- Second negative constructive 5 minutes

Five (5) minute break between constructive speeches and rebuttals.

- First negative rebuttal 3 minutes
- First affirmative rebuttal 3 minutes
- Second negative rebuttal 3 minutes
- Second affirmative rebuttal 3 minutes

A flowchart example of this schedule follows the rules section.

F. **First affirmative constructive:** States a reasonable interpretation of the resolution, and represents prima facie case for the adoption of the resolution (a case which, if not challenged, would lead a reasonable man to support the resolution). A summary of what the second affirmative will present may also be included. The affirmative team has the burden of proof in favor of the resolution.

First negative constructive: Offers arguments against the adoption of the resolution, and may respond directly to the first affirmative. The negative team must either use the affirmative team's interpretation of the meaning of the resolution, or else show that interpretation to be unreasonable. The negative team must disprove the resolution.

Second affirmative and negative constructive: Complete the constructive arguments of the respective teams, and present a brief summary of the team's position. These speakers may also offer refutation of previous speakers.

Rebuttal speeches: Rebuttal speeches focus the debate on contested issues, as the speakers attack opposing arguments and defend their own. No new issues or arguments may be brought up in rebuttal speeches, but new evidence may be introduced to support or refute any claim introduced in any constructive speech.

G. **Visuals:** Any visual aids used in the debate must be visible to both teams and the audience, and must be left available for reference by later speakers. Posters or charts are to be left on display throughout the debate following their introduction. Electronic visual aids must be battery operated.

JUDGING

A. One of the judges, previously designated as the room chairman, will preside over the debate. His duties include:

1. To briefly welcome those present.
2. To ascertain that a timekeeper is present and ask for a volunteer, if necessary.
3. To ask the speakers to introduce themselves, by name only, with no identification of their congregation or hometown.
4. When all judges, the timekeeper, and participants are ready, to call for the debate to begin.
5. When time is up on the last speech, to announce the end of the debate and to thank the speakers, timekeeper, and audience, but not to announce the judges' decision on the debate.
6. To take charge of the judges' score sheets and deliver them to the debate coordinator following the event.

B. Timekeepers

1. The timekeeper will be a volunteer from the audience, or, if necessary, one of the judges may also keep time.
2. The timekeeper will display silent signals for each minute of elapsed time, and an audible signal will be given at the end of each speaker's allotted time. When the timekeeper signals that time has expired, the speaker should stop speaking or otherwise be subject to penalties.

C. Penalties

1. Speakers will be penalized one point for each new issue introduced in a rebuttal speech.
2. Speakers will be penalized one point for each 30 seconds or part thereof over the time limit.

AWARDS

A. First, second, and third place awards will be presented to the highest scoring speakers.

B. First, second, and third place awards will be given to each member of the highest scoring teams.

JUDGES' INSTRUCTIONS FOR DEBATE

1. Use one Debate Team Score Sheet for each team for the whole debate.
2. Write the speakers' names in the spaces provided.
3. Circle whether the team is on the affirmative or negative side.
4. Assign a numerical value 1-5 (5 being best) to each category covered on the form.
5. At the end of the debate, total the number of points for each speaker, deducting any penalties.
6. Transfer total points for individual speakers to the summary sheet.
7. Select the overall winning team in the debate. This should be the team which most effectively defended its assigned position on the resolution. It may or may not be the team with the most speaker points from the team score sheet. The winning team gets a 5-point bonus.
8. Add each team's total points, attach all score sheets, and turn in to the room chairman.

NOTE: JUDGES ARE NOT TO LET THEIR PERSONAL VIEWS ABOUT TOPICS INFLUENCE THEIR DECISION FOR OR AGAINST ANY TEAM. SCORES SHOULD BE BASED ON THE EFFECTIVENESS OF THE DEBATERS.

The following flowchart illustrates how the debate will proceed.
 For illustration purposes:
 Team 1 is Bob & Steve Team 2 is Joe & Andrew

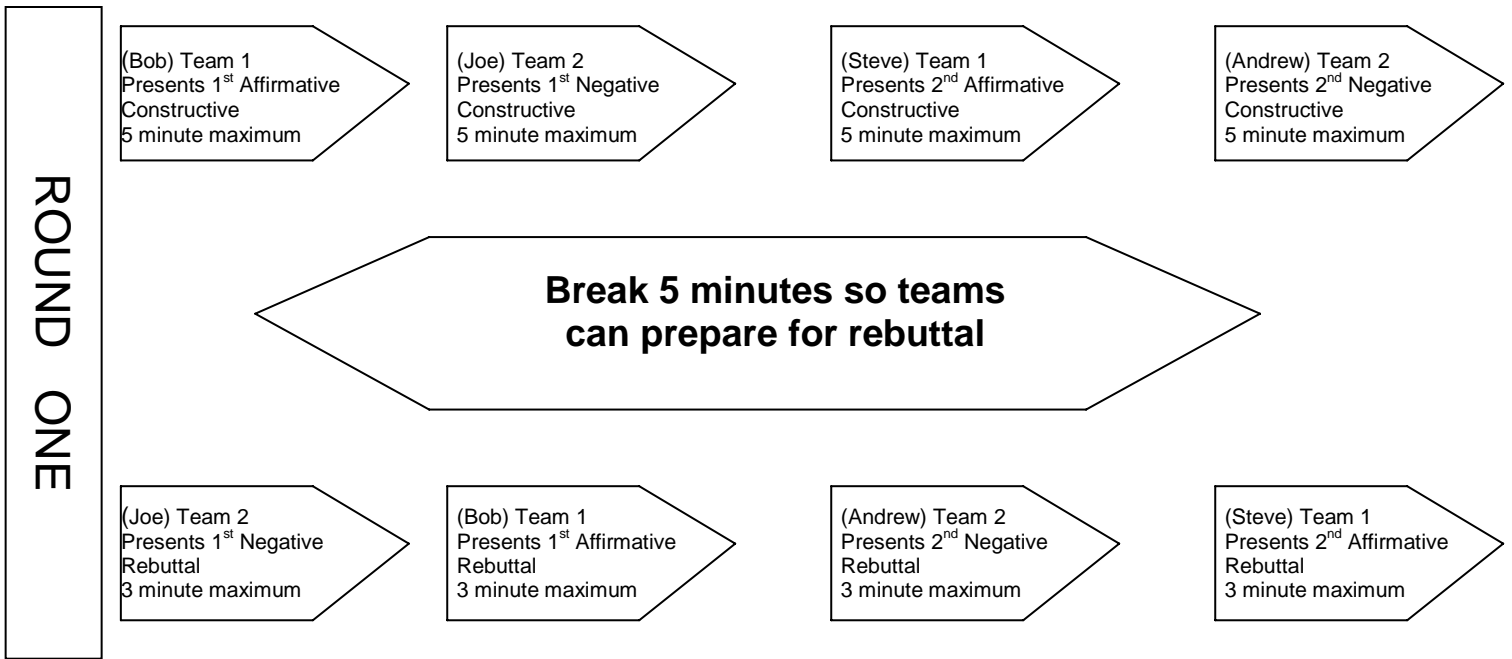

5 MINUTE BREAK BEFORE ROUND TWO

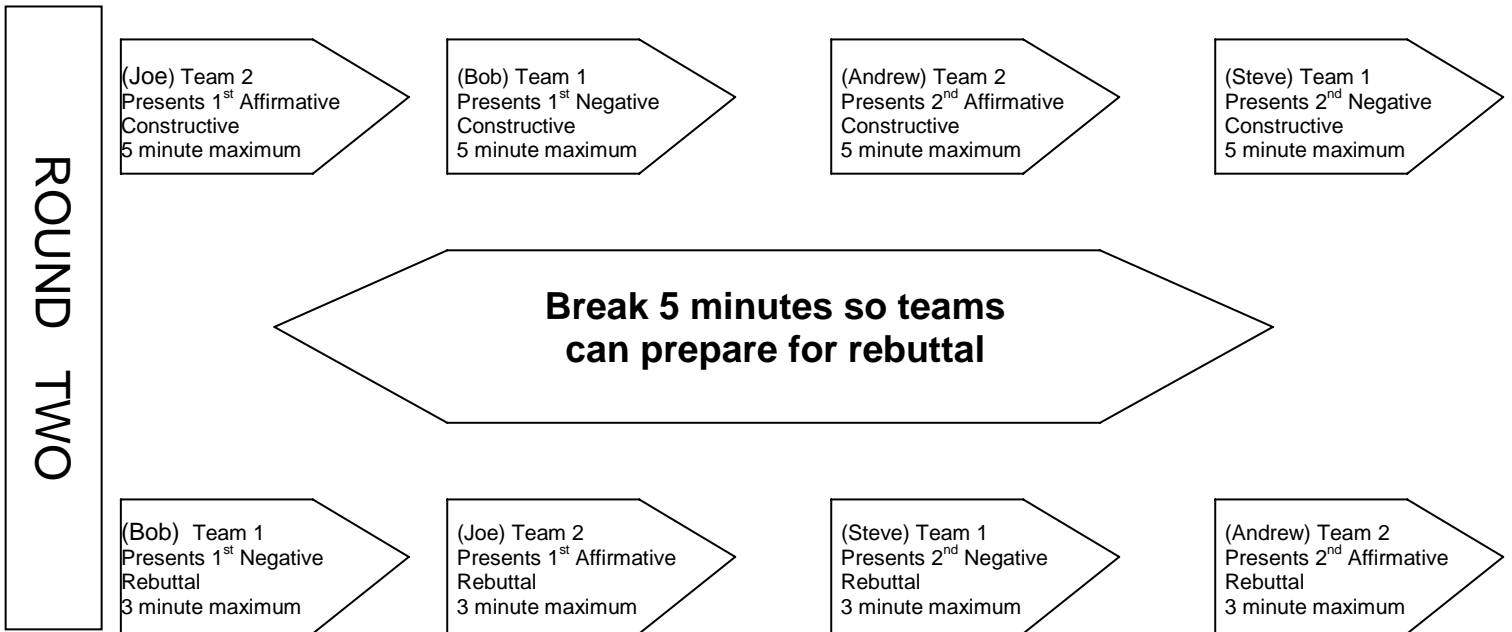

GIFTS

Girls in Fellowship and Team Study

This is a non-competitive event... one competes only with self.

PURPOSE

To foster a spirit of cooperation and fellowship among Christian teen girls, and to develop a spiritual relationship and dependence on one another for strength to overcome temptation and serve faithfully. To grow in the ability to lead and participate in ladies' Bible classes.

EVENT PARTICIPATION

Open to Leaderettes in grades 6-12. GIFTS is not recommended for girls younger than sixth grade. Materials may be ordered from the National Service Center.

EVENT RULES AND GUIDELINES

- A. Study groups of at least three girls (grades 6-12) are formed within the congregation. There should be no more than 10 girls in a study group. If a congregation has fewer than three teen girls, they can include girls from other area congregation(s) in the study.
- B. Each study group must have at least one adult female mentor who is responsible for tracking the progress of each group member.
- C. Study/fellowship groups must meet monthly for four consecutive months at any time during the year prior to the convention deadline.
- D. Sessions should begin and end with prayers led by group members. Prayer requests should be taken and honored at the time of the opening prayer.
- E. Each session should cover a chapter in the GIFTS curriculum (available for purchase through the National Service Center).
- F. Each session should be led by a predetermined group member, but all members should participate in the discussion. The mentor should be present to facilitate the discussion and answer any questions that may arise.
- G. Three of the projects at the end of each chapter should be chosen and completed by the girls prior to the next meeting. The girls may all choose the same projects or may choose different ones.
- H. In the case of the fourth session, the team members should arrange a convenient meeting place and time for the mentor(s) to check the projects from the final session.
- I. Mentors should complete the GIFTS verification form (available in the Entry Forms and Log Sheets section of the Rules Book page of our website) and sign it for submission to the Team Leader by the convention registration deadline date. The forms do NOT need to be mailed to the National Service Center. **Group leaders are to electronically verify each participant of this event in the registration system.**
- J. Girls may qualify for GIFTS II recognition only after completing and receiving recognition for GIFTS I.
- K. Girls may qualify for GIFTS III recognition only after completing and receiving recognition for GIFTS II.
- L. GIFTS III will include five sessions, including additional projects.

AWARDS

There will be recognition at the annual convention for all Leaderettes who complete each level. Only one level may be completed per convention year.

GUARD

Guys Understanding Authority and Real Discipleship

This is a non-competitive event... one competes only with self.

PURPOSE

To foster a spirit of cooperation and fellowship among Christian teen boys, and to develop a spiritual relationship and dependence on one another for strength to overcome temptation and serve faithfully. To grow in the ability to lead and participate in Bible classes and worship services.

EVENT PARTICIPATION

Open to Lads in grades 6 - 12. GUARD is not recommended for boys younger than sixth grade. Materials may be ordered from the National Service Center.

EVENT RULES AND GUIDELINES

- A. Study groups of at least three boys (grades 6 - 12) are formed within the congregation. There should be no more than 10 boys in a study group. If a congregation has fewer than three teen boys, they can include boys from other area congregation(s) in the study.
- B. Each study group must have at least one adult male mentor who is responsible for tracking the progress of each group member.
- C. Study/fellowship groups must meet monthly for four consecutive months at any time during the year prior to the convention deadline.
- D. Sessions should begin and end with prayers led by group members. Prayer requests should be taken and honored at the time of the opening prayer.
- E. Each session should cover a chapter in the GUARD curriculum (available for purchase through the National Service Center).
- F. Each session should be led by a predetermined group member, but all members should participate in the discussion. The mentor should be present to facilitate the discussion and answer any questions that may arise.
- G. Three of the projects at the end of each chapter should be chosen and completed by the boys prior to the next meeting. The boys may all choose the same projects or may choose different ones.
- H. In the case of the fourth session, the team members should arrange a convenient meeting place and time for the mentor(s) to check the projects from the final session.
- I. Mentors should complete the GUARD verification form (available in the Entry Forms and Log Sheets section of the Rules Book page of our website) and sign it for submission to the Team Leader by the convention registration deadline date. The forms do NOT need to be mailed to the National Service Center. **Group leaders are to electronically verify each participant of this event in the registration system.**
- J. Boys may qualify for GUARD II recognition only after completing and receiving recognition for GUARD I.
- K. Boys may qualify for GUARD III recognition only after completing and receiving recognition for GUARD II.
- L. GUARD III will consist of five sessions, including additional projects.

AWARDS

There will be recognition at the annual convention for all Lads who complete each level. Only one level may be completed per convention year.

GOOD SAMARITAN

This is a non-competitive event...one competes only with self.

PURPOSE

To reach out to others by going the extra mile. To teach the importance of showing people other than family the love of Jesus. This can be done by sending cards, visiting the sick and shut ins, conducting home Bible studies, performing service projects, etc. Being a Good Samaritan means going beyond our Christian living.

EVENT PARTICIPATION

- A. Adults and students can participate. This is a project that can be done individually, by pairs, or by the youth group. The students should encourage each other and work together (promoting cooperation), **but the units are to be recorded on an individual basis.** No one should go visiting alone. Students should not go out on their own without adult supervision or unless they are in a group. **Family responsibilities are NOT considered Good Samaritan services. No points should be accumulated for this.** Teaching children about working in the home or yard is a parent's responsibility, and the work is not a Good Samaritan service. Helping or serving members of the congregation, someone in the community, or someone in need is an example of Good Samaritan service. Remember, most people will send cards or visit their relatives. A Good Samaritan is not one that merely lives a Christian life, but one that serves by going the extra mile.
- B. Team leaders have the full discretion to decide the point system for their students. The following is a sample list of projects that are all to be done in the name of Jesus:
1. Sending cards to sick or shut-ins: 5 units for each card sent. Give extra points if the card is homemade.
 2. Phone calls to those who are sick or shut in: 5 units for each call.
 3. Visits to home, hospital, funeral home, or nursing home: 10 units for each visit.
 4. Inviting visitors to church or youth activities: 10 units for each visitor per visit.
 5. Conduct Bible studies in your home: 20 units for each person at the study.
 6. Participating in mission trips: 500 units per trip
 7. Service projects: 10 units for each hour of service. Projects include:
 - Cutting grass for the elderly or handicapped.
 - Cleaning the church building.
 - Cleaning the house of an elderly or handicapped person.
 - Cleaning at a city park.
 - Helping the elderly or a mother with children.
 - Helping mothers with children by babysitting.
 - Planting flowers in public places.
 - Any other deeds, approved by the local congregation, that benefit someone else without receiving any compensation in return and also glorify God.
- C. Group leaders should monitor unit value based on projects. We are trying to encourage quality and meaningful projects. **GROUP LEADERS: Do NOT send log sheets to the National Service Center. However, these log sheets are required for Jonathan Bourland nominations. Group leaders are to electronically verify each participant of this event in the registration system.**
- D. Points are accumulated from registration deadline to registration deadline each year, not from convention to convention.
- E. A sample form is provided for record keeping. Parental guidance is allowed in filing out the forms. **ALL work must be completed prior to the convention registration deadline. If work is not completed, DO NOT register a person for this award.**

****Verification forms/lists do NOT have to be mailed to the National Service Center.****

AWARDS

- A. Group leaders should stress that the joy of being a Good Samaritan is the greatest reward. Units and material awards are always secondary to the spiritual blessings of helping others.
- B. Awards may be earned on three levels:
 - Bronze 500 units
 - Silver 800 units
 - Gold 1000 units
 - Platinum 1500 units
- C. Only one medal per participant each year. No multiple awards.

The following are thoughts and reasons for doing the Good Samaritan program:

Matthew 6:1-4 warns us to take heed not to do our charitable deeds before men, to be seen of them. It says that the hypocrite blows a trumpet so that men will see what he is doing. "Do not let your left hand know what your right hand is doing, that your charitable deeds may be in secret." (Matthew 6:3-4)

This raises some interesting questions: Should you use a check that has your name on it when you give your contribution? When you donate to a mission work or orphanage, should you do so anonymously? If you take food to a needy family, should you run away after you leave the food at the door? Is it wrong to be honored with your name on a building at a Christian College? What about a library or school? What about a pew or songbook that has some note identifying the benefactor?

The key word in this passage is "hypocrite." He pretends to be something he is not. He pretends to love God and other people but inside he does not. The word literally means an actor. He is playing a role or part just like an actor in a Shakespearian drama. This type of hypocrisy is always condemned.

The hypocrite of Matthew 6:1-4 does not have the right motive in his heart. He is not true to his beliefs, but pretends to care about others. When we see the works of a person with a pure heart "shining" before men, it glorifies God.

I Peter 2:12 points out that your good works will be observed by others and God glorified. How can this be if all our acts of kindness are done anonymously? If no one knows who fed the hungry or mowed the yard for the elderly, how is God glorified? How are we leading others to Christ if they have no idea who left the food at their door?

The real issue is our motives. If a person does a good deed with an evil heart, he is like Ananias and Sapphira of Acts 5. They were hypocrites. If his heart is pure, like Barnabas, he encourages others and God is glorified (Acts 4:36). We should let our lights shine. Do not hide them under a bushel (Matthew 5:14-15). Always remember to give God the glory.

Should we recognize and honor those who have done good deeds? Certainly!! Note how many people Paul mentioned by name. He honored them and their good works by placing their names in the scripture for us to read about today. Would it have been better if Barnabas had sold his land and given it anonymously? Could he be blamed for the hypocrisy of Ananias and Sapphira?

Was little boy David a hypocrite? In I Samuel 17:25 David heard the men of Israel say that whoever kills the Philistine will get great riches, no taxes and the King's daughter. In the very next verse, verse 26, he asks for clarification about the reward. He said, "What shall be done for the man who kills the Philistine?" David wanted to know about the earthly reward. How much of a motivator was it for him? We will never know. This could have been a factor in motivating him to face the giant.

David trusted the Lord to deliver him, not himself. He said "the battle is the Lord's." God gave him the victory. Was he a hypocrite like the man in Matthew 6:1-4? Absolutely not!! He had God in his heart. The earthly reward was just a motivator to help get him started. He was no actor or hypocrite.

Just as little boy David needed a jump start to get him going, sometimes we do. Having a star beside your name for Sunday school attendance, being presented a Bible for bringing the most VBS visitors or receiving a Good Samaritan medal might be just the right ticket.

Remember – do not be a hypocrite or an actor. Have the love of God in your heart and give God the glory.

JONATHAN BOURLAND MEMORIAL HUMANITARIAN AWARD

(An Extension of the Good Samaritan)

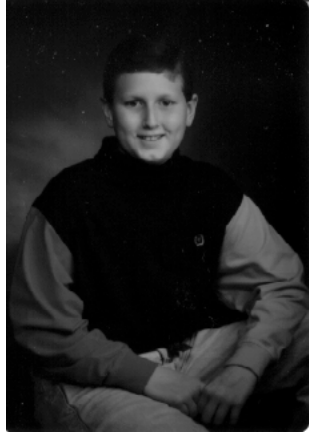

Jonathan Lee Bourland
1981-1994

JONATHAN BOURLAND

Though only with us for 13 short years, Jon taught us how to love God, treasure life and be an encouragement to all people. Jonathan Bourland was one of a kind. He was diagnosed with Ewing's Sarcoma when he was 9 years old. However, Jon never missed a step. He went to school, church, ball games, etc., as his health permitted. While being physically weak from the illness, Jon encouraged his friends with his inner strength and positive attitude.

The Jonathan Bourland Award is an extension of the Good Samaritan Award. Jon was always willing to do more than was asked or expected. This award in his honor is for young men and women who are willing to go beyond the extra mile to teach, serve and encourage others.

We thank Rick and Debbie Bourland of Sheffield, AL for sharing the short life of their son with all of us. His character and strength will always be carried in our hearts.

- By Betsy Morris
Highland Park Church of Christ
Muscle Shoals, Alabama

PURPOSE

To acknowledge youth and adults who go beyond that which might be expected in serving and teaching others. To recognize those who set a Christian example through their attitude and service toward others. This award is an advanced extension of the Good Samaritan Award.

EVENT PARTICIPATION

Students and adults are eligible for nomination. Men and women are judged together in the following divisions:

- Grades 3-6
- Grades 7-9
- Grades 10-12
- College-Adult

REQUIREMENTS

- A. The period of time between conventions must be spent with the student consistently working in some manner to help others by meeting qualifications for the Good Samaritan Award.
- B. Group leaders should monitor unit value based on projects. We are trying to encourage quality and meaningful projects.
- C. Records are to be kept in order to verify the student's consistent work and progress. **A copy of these records is to be sent along with the Good Samaritan form and log sheets and the Jonathan Bourland form.** A copy of these records should be kept by the participant.
- D. Each congregation may select the top Good Samaritan entries who have worked the entire year in service for our Lord.
- E. Those who are nominated and selected for this award should be the elite of those who strive to be Good Samaritans. Nominations will be received from church leaders, mentors, teachers, and parents. Nominations should come as a result of others commending your work, individuals should not nominate themselves. The element of surprise is one of highlights of this award.
- F. The nomination form and all supporting documentation must be mailed to the address shown in the Convention Information section of the Lads to Leaders website by the registration deadline. The form is located in the Entry Forms and Log Sheets section of the Rules Book page of our website.

AWARDS

Awards will be given in each division.

HOST & HOSTESS

PURPOSE

To serve at the convention. Host and Hostess are selected students who will show exceptional hospitality and will be friendly and helpful. They will greet, guide, assist individuals or groups, and will put a gracious touch to the convention. They are to give a warm, friendly attitude of “We are glad you are here” and “How can I help you?”

SELECTION PROCESS

To be selected to serve as Host and Hostess is an honor. Hosts and Hostesses will be selected according to the following procedures.

- A. Students may be nominated from any of the following applications.
 1. Students wishing to serve must notify their group leader who can register them on the Convention Registration database.
 2. Congregations may suggest specific students of outgoing personality and helpful nature.
 3. National Service Center may submit names from workshops and scholarship applicants. National Service Center will refer names to coordinator.
 4. Board members and coordinators may submit names to the coordinator of Host and Hostess.
- B. From applicants submitted, students will be selected for the honor using the following criteria:
 1. Considering the total number of applicants, a high percentage of seniors and juniors will be selected and a lesser percentage from grades 7-10.
 2. Students must be available from noon Friday through the Saturday night Awards Ceremony. However, this will not take away from their own participation.
- C. The coordinator will send an invitation to the student or team leader and request a RSVP by a specific date. If no RSVP is received by the date, the name will be dropped and another student will be contacted.

GUIDELINES

- A. Availability
 1. Be available for instructional meeting by coordinator Friday noon or before (time to be arranged).
 2. Be available Friday noon through Saturday night awards on a rotational basis that coordinator will set. This is not to cause any problems with students' personal events.
- B. Dress
 1. Group Leaders: Make sure your participants are dressed properly-modestly and appropriately. It is a positive or a negative reflection on your congregation. Attire for Friday noon-Saturday: church dress, pantsuits, sport coats, etc. (no t-shirts, jeans or shorts.)
 2. Attire for awards ceremonies: Sunday church attire, informal or formal. **No strapless, no spaghetti straps, no too low cut, no short or tight dresses. Remember that you represent Christ and His Church. Students are encouraged to look their best as Christian examples. Students dressed immodestly will be dismissed from their service.** While a participant's presence may complement an event, it is not to be a distraction.
- C. Assignments
 1. Assignments will vary (greeter, guide, trophy distribution, etc). If more students have been assigned to a post than needed, communicate to the Host and Hostess coordinator because there may be a shortage elsewhere. If stationed at an awards stage, do not block the view of the audience or photographers.
 2. Whatever the assignment, make it a service of joy by meeting new people and making them feel comfortable. Some assignments may be:
 - Greet people as they arrive and ask if you can help them.
 - Distribute trophies at the awards ceremonies.
 - Guide people to various events and around the hotel.
 - Be able to answer questions.

JUNIOR LEADER

This is a non-competitive event... one competes only with self.

PURPOSE

To instill basic leadership skills in young participants. Participants study Bible leaders and the leadership qualities that they had both good and bad. Participants will complete practical projects that will benefit the local congregation and community.

EVENT PARTICIPATION

Open to boys and girls from grades K-5, this material can be taught in Bible class, home school or other group sessions. Participants do not have to attend convention to participate in this non-competitive event. Participation in this study is on a local level. While this is not a convention event, participants who earn awards may have their names listed in the program at convention.

EVENT RULES AND GUIDELINES

- A. The participant may progressively participate from year to year until they are above a 5th grade level or until they have achieved all three levels of Junior Leader.
- B. Levels and requirements are as follows:
 - Level I: Complete chapters 1-4 in the Junior Leader book and complete one project per chapter for a total of 4 projects.
 - Level II: Complete chapters 5-8 in the Junior Leader book and complete one project per chapter for a total of 4 projects.
 - Level III: Complete chapters 9-13 in the Junior Leader book and complete one project per chapter for a total of 5 projects.
- C. There are two levels of Projects. Servant level indicates projects that are easier to complete and are suitable for those who are younger. Skilled level indicates projects that are more challenging for this age group and are for those who are older. It will be the prerogative of the adult mentor and/or church leadership to determine which level projects a student should complete.
- D. Games, Activities and Crafts will be rated either servant or skilled for the benefit of the adult mentor in choosing activities appropriate for the class.

AWARDS

JUNIOR LEADER I, II AND III certificates will be sent with the material to the adult mentor overseeing the event. The adult mentor will present the certificates as participants complete the different levels of the event. Upon completion of Junior Leader III, a final award will be sent to the adult mentor for presentation to the participants(s) on the local level. **Group Leaders: Verification forms (available in the Entry Forms and Log Sheets section of the Rules Book page on our website or in the Junior Leader book) for each participant should be mailed to the National Service Center ONLY if you wish to have their names listed in the convention program. There is no official deadline for completion of Junior Leader. However, if you would like the names of the children who have completed Junior Leader to be printed in the convention program, then we will need to receive the verification form by the registration deadline.**

KNOW THE BOOKS

This is a non-competitive event... one competes only with self.

Purpose: To teach the books of the Bible and their themes.

Participants:

- Level One – Children through Grade 2
- Level Two – Grades 3-6
- Level Three – Grade 7-Adults

Requirements for:

- Level One – recite or sing the books of the Bible in order.
- Level Two – recite the books of the Bible in order.
- Level Three – recite the books of the Bible, along with their themes, in order. **Note: Adding themes to the older group makes the event a greater challenge. A list of suggested themes for each book is on the next page.**

This event will be completed in the home congregation and **group leaders are to electronically verify each participant of this event in the registration system.** Awards will be provided to the team leaders in the registration packets at convention. Participants will be recognized during the Friday evening awards ceremony. Awards for all three levels should be presented at the local awards ceremony after convention.

****Verification forms/lists do NOT have to be mailed to the National Service Center.****

Award Levels:

- Bronze – for reciting the New Testament books.
- Silver – for reciting the Old Testament books.
- Gold – for reciting both the Old and New Testament books.

Suggested Themes for Know the Books

Suggested Old Testament Themes

1. Genesis – beginnings
2. Exodus – a nation starts
3. Leviticus – worship laws
4. Numbers – sin and God's mercy
5. Deuteronomy – review of the law
6. Joshua – the promised land
7. Judges – Israel tested and delivered
8. Ruth – loyalty
9. 1 Samuel – from judges to kings.
10. 2 Samuel – David's reign
11. 1 Kings – Solomon and the divided kingdom
12. 2 Kings – the divided kingdom to captivity
13. 1 Chronicles – the reign of David
14. 2 Chronicles – Solomon and other kings of Judah
15. Ezra – remnant returns
16. Nehemiah – rebuilding the walls of Jerusalem
17. Esther – God's providence
18. Job – pain and suffering
19. Psalms – worship
20. Proverbs – wise sayings
21. Ecclesiastes – material goals are empty
22. Song of Solomon – beauty of marital love
23. Isaiah – the prophet of God's rule
24. Jeremiah – the prophet of failure
25. Lamentations – Jeremiah's sorrow
26. Ezekiel – the prophet of hope
27. Daniel – the prophet of dreams
28. Hosea – spiritual adultery
29. Joel – day of the Lord
30. Amos – seek the Lord and live
31. Obadiah – God punishes Edom
32. Jonah – God loves the Gentiles
33. Micah – consequences of sin
34. Nahum – Nineveh's downfall
35. Habakkuk – the just live by faith
36. Zephaniah – God's goodness and severity
37. Haggai – build the Lord's house
38. Zechariah – judgment and encouragement
39. Malachi – God's people rebuked

Suggested New Testament Themes

1. Matthew – Jesus, the King
2. Mark – Jesus, the servant
3. Luke – Jesus, the man
4. John – Jesus, the Word of God
5. Acts – the Church
6. Romans – righteousness revealed
7. 1 Corinthians – Church problems
8. 2 Corinthians – be reconciled to God
9. Galatians – Christian liberty defended
10. Ephesians – Christ and His Church
11. Philippians – Christ, the secret of joy
12. Colossians – the pre-eminence of Christ
13. 1 Thessalonians – the 2nd coming of Christ
14. 2 Thessalonians – the day of the Lord
15. 1 Timothy – order in the Church
16. 2 Timothy – the true minister of Christ
17. Titus – believer's Godly life
18. Philemon – treatment of a brother
19. Hebrews – our great High Priest
20. James – true faith produces works
21. 1 Peter – comfort for the suffering Christians
22. 2 Peter – warnings against false teachers
23. 1 John – Christ and fellowship with God
24. 2 John – warnings against deceivers
25. 3 John – receive true believers
26. Jude – contending for the faith
27. Revelation – victory

MASS MEDIA

PURPOSE

To train Christians to use the media effectively. In the current age of information and technology, more Christians need to be in the world of mass media.

EVENT PARTICIPATION

- A. Students may participate in any or all of the following five categories:
 1. Article/Editorial
 2. Audio Presentation (CD format)
 3. Storyline (DVD format)
 4. Video Presentation (DVD format)
 5. Website
- B. In each category of participation, there will be three divisions:
 - Grades 3-6
 - Grades 7-9
 - Grades 10-12
- C. In the Storyline and Website events, boys and girls may participate together in teams or individually. In all other categories, boys and girls will participate separately.

GENERAL EVENT RULES AND GUIDELINES

- A. **Make sure that you send your entries to the Mass Media Coordinator for your designated convention and NOT the National Service Center. We cannot guarantee that your entry will be judged if you do so.**
- B. Quality presentations are needed so that your hard work will be useful instead of being shelved and never used again. DVD's may be submitted for Storyline or Video Presentation. CD's may be submitted for Audio Presentation.
- C. Entrance requirement – Participants attending the annual Convention should register as in other events. Those not attending the Convention should register as well.
- D. There should be only **ONE** presentation per CD or DVD for all entries. **ONLY** the version of the presentation that is to be judged may be on the CD or DVD.
- E. **A written script must accompany all presentations, or the entry will be ineligible.**
- F. Identification of Participants:
 1. A completed official entry form must accompany all entries.
 2. Participants must not be identified directly on the tape, CD or DVD by name, geographical location, or congregation. **Note: To ensure proper identification of an unlabeled tape, you must place the CD or DVD, along with the Mass Media Entry Form, in a Ziploc bag. Make sure that the form shows through the Ziploc bag so that we can identify your congregation and entry category of participation without opening the bag. These are to be mailed to the Lads to Leaders National Mass Media Coordinator for your respective convention location (NOT the National Service Center). Addresses are available on the website.**
- G. Each CD or DVD should be accompanied by the following written documentation:
 1. The completed Mass Media official entry form.
 2. A written script of the presentation.
- H. **All entries must be postmarked and sent, along with the official entry sheet and any other documentation required, to the Mass Media Coordinator for your group's convention location by the convention registration deadline. Late entries are ineligible. Please indicate your group name on the outside of the envelope to help the coordinator with sorting entries.**

- I. All CD's and DVD's as well as all written work (i.e., speeches, articles, editorials, and storylines), will become property of Lads to Leaders and will not be returned. **Please make personal copies before submitting entries.** This material will be used to train and to encourage other groups as they prepare for the event.

JUDGING

- A. Judges for each category will be selected based on their expertise in the various categories of mass communication.
- B. Each category of participation will follow its own event rules.

AWARDS

First, second, and third place awards will be given for each category in each division.

ARTICLE/EDITORIAL

EVENT RULES AND GUIDELINES

Additional rules concerning this event are included in the Mass Media section of this document.

- A. This event involves a written article or editorial suitable for publication in a periodical such as *Gospel Advocate*, *Christian Woman* or *church bulletin articles*. Lads to Leaders & Leaderettes may use any article/editorial for marketing purposes and/or submit it for publication. The following guidelines apply:
 1. The content of the article should be related to the selected Convention theme and Biblically accurate.
 2. The entry must not be a speech, but an article or editorial prepared for publication.
 3. The article/editorial must be between 200-250 words.
 4. The article/editorial must be typed double-spaced and must fit on the front of **one** page.
 5. The article/editorial **must** be the work of and be written completely by the student. Adults, however, may proof for spelling errors or arrange for the material to be typed.
- B. Rules regarding identification of participants:
 1. A cover sheet should be attached to the article. The cover sheet will include the name and address of the student, the name and address of the student's congregation and the date. This will be separated from the entry by the coordinator and will not be penalized as self-identification.
- C. Criteria for Scoring
 1. Content (Biblical accuracy, clarity of principle presented).
 2. Adherence to Convention theme.
 3. Composition (introduction, development of thought, conclusion or summary statement).
 4. Grammar, syntax, and vocabulary (actual use of the language).
 5. Reader appeal (creativity, timeliness, and continuity of thought).
- D. Penalties
 1. Any self-identification by the participant will be penalized three points.
 2. Students will be penalized two points for one to 25 words over or under the word limit; four points for 26 to 50 words over or under the word limit; etc.
 3. Twenty points will be deducted if not double-spaced and typed.

JUDGES' INSTRUCTIONS FOR ARTICLE/EDITORIAL

Points will be awarded to participants in the following categories:

- A. Content – 20 points (Biblical accuracy, clarity of principle presented)
- B. Adherence to theme – 15 points
- C. Composition – 25 points (Introduction, development of thought and summary)
Judges will critique organization and structure in the student's writing. The flow of the student's thoughts should be smooth and logical in order.
- D. Grammar, syntax, and vocabulary – 20 points
Proper grammar, vocabulary and sentence structuring should be found in the composition.
- E. Reader Appeal – 20 points (Creativity, timeliness, continuity of thought)
Figures of speech, similes, metaphors, colorful choice of words, and zestful, descriptive phrases are important qualities. The writing should be interesting for the reader from beginning to end.

AUDIO PRESENTATION

EVENT RULES AND GUIDELINES

Additional rules concerning this event are included in the Mass Media section of this document.

- A. Audio composition involves a CD recording. The presentation should be in a public service announcement (PSA) format or similar to 30-second informational “commercials” that ministries use on radio. The participant should assume the role of a radio speaker. This message must be different from the material used in video presentation. The medium is different, thus the presentation should be different.
- B. The content of the CD should be based on the selected annual convention theme.
- C. There should be only **ONE** presentation per CD for all entries. **ONLY** the version of the presentation that is to be judged may be on the CD.
- D. Time limit and penalties:
 1. Presentation must be 20 to 30 seconds for all ages.
 2. Students will be penalized two points for one to five seconds over or under the time limit; four points for six to 10 seconds over or under the time limit; etc.
 3. Any self-identification by the participant shall be penalized three points.

JUDGES' INSTRUCTIONS FOR AUDIO PRESENTATION

Although the technical aspects of audio presentation, such as sound levels, background noise or music, editing, etc., are important to quality, these are not specific categories of judgment for this event. However, audio quality is very important and certainly influences the overall impression and effectiveness.

Points will be awarded to participants in the following categories:

- A. Content – 20 points
(Adherence to theme, clarity of principle presented, Biblically accuracy)
- B. Organization Quality – 30 points
(Creativity, value, logic, color)
In this category, only the material and its organization, as presented by the participant, should be judged. One should consider the importance of creativity for such a short format, the proper introduction of the subject and the logical and coherent development of the theme which brings about a successful and adequate conclusion. Figures of speech, similes, metaphors, colorful choice of words, and zestful, descriptive phrases are important qualities.
- C. Delivery and Presentation – 30 points
(Voice, enunciation, pronunciation, sincerity, and emphasis)
Delivery and presentation shall be on several factors. Voice quality should be recognized in tone, pitch, and volume. Delivery should be continuous, without hesitation or halting. Enunciation and pronunciation are most important. Sincerity and enthusiasm are important qualities. Desire to be convincing should be obvious; emphasis should be well-placed and dynamic.
- D. Overall Effectiveness – 20 points
(Appeal, impression, effect, format)
In this category, the overall impression created by the orator and the oration should be rated. In any event of this type, the overall impression of a specific effect is a result of many factors, some of which are indefinable and inexpressible and cannot be individually scored. This category is where you value the overall impression.

STORYLINE

EVENT RULES AND GUIDELINES

Additional rules concerning this event are included in the Mass Media section of this document.

- A. This event involves a dramatized Bible story, Bible truth, or moral lesson presented on a DVD. There should be only **ONE** presentation DVD for all entries. **ONLY** the version of the presentation that is to be judged may be on the DVD. Participants use live dramatization (no puppetry, please) adhering to the following guidelines:

1. The content of the Storyline should be related to the selected Convention theme and Biblically accurate.
 2. The Storyline presentation should be a team effort involving **no fewer than three active team members and no more than 15. This number does not include skits that use a larger number for a crowd scene.**
 3. Teams participate in the division of the oldest member of their group.
 4. Watch the finished entry prior to submitting it.
 5. If the video is edited with a computer, it must be rendered in a format which is compatible with a standard VCR. Remember to render the video with the same settings used for capture. Check with your video editing program for details. Typical settings include: Rate 48000; Format: 16 bit; Compression: uncompressed. If video is submitted on DVD, it must be compatible with a standard DVD player.
 6. Ensure that your script matches your video. Some congregations send videos with more than one age group and confuse the scripts.
 7. Audio must be reasonable quality in order for judges to understand. Try buying a microphone from Radio Shack which connects to the camera and has a long cord. Tape the microphone and cord to a broom stick or piece of PVC pipe and hold it over the actors, just out of camera view. This technique has brought a lot of success.
 8. Do not rely on fancy transitions or special effects. The story and the presentation of the actors is the most important aspect of the video. Transitions can make the video more interesting and appealing, but will not overcome a poor storyline or lack of Biblical message.
- B. Rules regarding time limits and penalties.
1. The Storyline must be three to four minutes in length for all ages.
 2. Students will be penalized two points for one to 10 seconds over or under the time limit; four points for 11 to 20 seconds over or under the time limit; etc.
 3. Any self identification by the participants shall be penalized three points.

JUDGES' INSTRUCTIONS FOR STORYLINE

Although the technical aspects of video presentation, such as lighting, transition shots, editing, etc., are important to quality, these are not specific categories of judgment for this event. However, Biblical message, video and audio qualities are very important and certainly influence the overall impression and effectiveness.

Points will be awarded to participants in the following categories:

1. Content (Biblical accuracy, adherence to theme, clarity of principle presented)
2. Creativity (Dramatization, sound effects, audience appeal)
3. Character Representation (Appearance, poise, personality, attitude)
4. Costumes (Authenticity, appearance)
5. Set (Authenticity, appearance, creativity)
6. Dialogue (Continuity, transition between characters)
7. Overall Effectiveness (Appeal, impression, effect)

VIDEO PRESENTATION

EVENT RULES AND GUIDELINES

Additional rules concerning this event are included in the Mass Media section of this document.

- A. Students are encouraged to think of the video event as preparing a presentation for television. The entry should be more than a speech delivered behind a podium and recorded on videotape. They should be creative in the way they present the material. **This is an individual event. Submit Storyline videos for groups.**
- B. The content should be based on the selected annual Convention theme.
- C. The video should be submitted on a DVD. There should be only **ONE** presentation per DVD for all entries. **ONLY** the version of the presentation that is to be judged may be on the DVD.
- D. Time limit and penalties

1. Presentations must be two-and-one-half to three minutes for all ages.
2. Students will be penalized two points for one to 10 seconds over or under the time limit; four points for eleven to 20 seconds over or under the time limit; etc.
3. Any self identification by the participant shall be penalized three points.

JUDGES' INSTRUCTIONS FOR VIDEO PRESENTATION

Although the technical aspects of video presentation, such as lighting, transition shots, editing, etc., are important to quality, these are not specific categories of judgment for this event. However, video and audio qualities are very important and certainly influence the overall impression and effectiveness.

Points will be awarded to participants in the following categories:

- A. Personal Qualities – 20 points
(Appearance, poise, personality, attitude)
- B. Material Organization – 30 points
(Biblical message, Subject adherence, scriptures, theme, value, logic, color)
In this category, only the material and its organization, as presented by the participant, should be judged. One should consider the importance of adherence to the subject of the oration, the proper introduction of the subject, and the logical and coherent development of the theme which brings about a successful and adequate conclusion. Figures of speech, similes, metaphors, colorful choice of words, and zestful, descriptive phrases are important qualities. The development of the material should be especially adapted for oral presentation.
- C. Delivery and Presentation – 30 points
(Voice, enunciation, pronunciation, gestures, sincerity, and emphasis)
Delivery and presentation shall be judged on several factors. Voice quality should be recognized in tone, pitch, and volume. Delivery should be continuous, without hesitation or halting. Enunciation and pronunciation are most important. Gestures should be appraised for frequency, nature, and effectiveness. Movement and gestures should not be awkward. Sincerity and enthusiasm are important qualities. Desire to be convincing should be obvious, emphasis should be well placed and dynamic.
- D. Overall Effectiveness – 20 points (Appeal, impression, effect)
In this category, the overall impression created by the orator and the oration should be rated. In any event of this type, the overall impression of a specific effect is a result of many factors, some of which are indefinable and inexpressible and cannot be individually scored. This category is where you value the overall impression.

WEBSITE

Individual/Group

PURPOSE

To expand students' influence to global proportions. Websites are accessible by anyone on the World Wide Web. Viewers need to see Jesus working in lives of students. The impression made through such a website may be the viewer's only experience of Christianity.

EVENT RULES AND GUIDELINES

- A. Websites may be created by individual students or a group of students. Websites will be evaluated in the grade division of the oldest student. They will not be judged as separate categories. For example, XYZ Church of Christ (with oldest student working on website in grade 10), John Smith (Grade 11), and ABC Church of Christ teen class (with oldest student working on website in grade 12) will all be judged together in grade division 10-12.
- B. **The website must be complete and accessible at the registration deadline.** An entry form **MUST** be mailed to the Mass Media coordinators by the registration deadline, in addition to being registered in the registration system. The entries are distributed to judges as soon as they are received. The website must be at the address listed on the form and entered in the online registration. Please check the entry carefully to ensure

that it is written and entered correctly. If the website cannot be accessed when the judges try, it cannot be judged.

- C. Participants are reminded of the implications of copyright law and of principles of fairness and originality.
- D. Websites must adhere to the National Convention theme.
- E. Pages should have more than a typed statement of some kind. Students may enhance their websites by using sound files, linked sites, or pages-behind-pages, etc. The work should be the student's in its entirety.

SUGGESTIONS

There are several sites that allow users, especially students, to establish a web site, complete with 5 megabytes or more dedicated storage space free of charge. Options include: www.angelfire.com and www.geocities.com. Additionally, most internet service providers will allow the same privileges to their customers.

AWARDS

First, second, and third place awards will be given for each grade division.

MUSIC COMPOSITION

PURPOSE

To encourage those talented in music composition to develop and use their talents for God. Also, young people who are encouraged to develop spiritual music composition talents are less likely to give much focus on questionable music. Because this event requires special talents or skills, we encourage each student to find a mentor from his/her local congregation or school who is musically proficient.

EVENT PARTICIPATION

- A. The music composition event will be held in the following divisions:
Grades 3-5 Grades 6-8 Grades 9-12
- B. Categories of participation for all grades:
 - 1. Participant's Original Lyrics Only OR Original Lyrics added to a known public domain or owner-released hymn.
 - 2. Participant's Original Melody Only OR Participant's Original Melody added to a known public domain or owner-released lyric, poem or Scripture, or added to participant's original lyrics from a previous convention.
 - 3. Participant's Original Harmony added to a known public domain or owner released lyric, poem or Scripture. Participant's Original Harmony Entries may be Two, Three or Four Part Harmony.

EVENT RULES AND GUIDELINES

- A. **Make sure that you send your entries to the Music Composition Coordinator for your designated convention and NOT the National Service Center. We cannot guarantee that your entry will be judged if you do so.**
- B. The participant may progressively participate from year to year with the same song, i.e., write the lyrics one year, add the melody the next, etc. Each element will only be judged the first year that it is entered. The participant may submit an entry that will be evaluated in multiple categories, as long as the parts to be evaluated are new for that year. For example, a student may submit an entry that contains new lyrics, melody and harmony to be evaluated in all three categories. Or, a student who wrote lyrics only one year can add melody and harmony to it the next year and have both the melody and harmony evaluated, but not the lyrics since they were submitted the previous year. When entries will be evaluated in multiple categories, make sure to mark the entry form correctly. Also, only one set of CDs and musical score need to be submitted, even if the entry is being evaluated in multiple categories.
- C. Be sure that any existing lyrics and music used is either public domain or that you have a release from the owner on any material still under copyright. Include copy of any such release with entry.
- D. Recruit some singers to record your composition, and work with your coach to teach them to sing it. Record the composition on a CD. All entries must include four (4) CDs with the entries on them. For Lyrics Only entries, the lyrics may be read or sung. Lyrics will be written to public domain or owner-released music OR with some "tune" in mind. Therefore, the Lyrics Only entries can be sung. If singing the lyrics is not possible, they may be read and recorded on a CD for submission.
- E. Musical instruments may be used for the production of the CD for entry of Original Melody Only. This is not to be construed as an endorsement for instrumental music to be used in worship. Submitting a melody only is an incomplete composition, therefore, it is not a worship song as of yet. Once lyrics have been added to the melody no CD with instrumental music may be submitted.
- F. Four copies of the CD (**including Lyrics Only entries**) should be accompanied with the following written documentation:
 - 1. One completed Music Composition official entry form (in the Entry Forms and Log Sheets section of the Rules Book page of our website).
 - 2. Four written copies of lyrics must be submitted.

3. Four copies of the musical score for all entries EXCEPT Lyrics Only. The composition must be written completely by the student. This includes grammar, punctuation and spelling for lyrics entries since these elements are being evaluated. An adult may type the lyrics for the student. The musical score must also be written by the student. The musical score may be handwritten (legibly) by the student or computer generated. **Entries (other than lyrics only) that do not submit the musical score on paper will not be judged.**
 4. One copy of any necessary releases.
- G. Participants must not be identified directly on the CD or the sheet music by name, geographical location or congregation. **Put only the title of the song on the CD and manuscript or sheet music. Note: To ensure proper identification, you must place all of the copies of the CDs, along with the above mentioned papers, in one Ziploc bag. Make sure that the form shows through the Ziploc bag so that we can identify your congregation and entry category of participation without opening the bag.** These are to be mailed to the Lads to Leaders National Music Composition Coordinator for your respective convention location (NOT the National Service Center). Addresses are available on the website.
 - H. **All** entries must be postmarked and sent, along with the official entry sheet and any other documentation required, to the Music Composition Coordinator for your group's convention location by the convention registration deadline. Late entries are ineligible. Entries are NOT to be sent to the National Service Center. The addresses for each convention location can be found in the Convention Information section of the Lads to Leaders website.
 - I. All CDs and sheet music will become the property of Lads to Leaders and will not be returned to you. **Please make personal copies before submitting your entries.**
 - J. All entries must be registered. Non-registered entries will be ineligible.

JUDGING

- A. Every attempt shall be made to ensure fairness in evaluating the participants.
- B. Each congregation is asked to provide a judge if qualified personnel are available (i.e., music training or background; song leader). Judges do not have to attend the convention.
- C. Three judges, preferably with music backgrounds, will work independently to examine, listen, and score each entry. The combined totals of all judges will determine the winners.
- D. Each judge should be familiar with all the event rules. The judges must use the official Scoring Sheets furnished.
- E. The results of a judge's decision will be kept confidential.
- F. Penalties:
 1. Any self-identification by participant will be penalized five points.
 2. Three points shall be deducted for each of the following:
 - a. Less than 16 measures or two lyric lines.
 - b. Less than four copies of manuscript (for Lyrics Only); less than four copies of the musical score submitted for all entries other than Lyrics Only.
 - c. Less than four CD copies submitted.
 3. Non-registered entries will not be judged.
 4. **Lyrics Only entries without the lyrics submitted on paper will not be judged.** Entries (other than Lyrics Only entries) that do not submit the musical score on paper will not be judged.
 5. Any entry submitted without the required CDs will not be judged.

AWARDS

First, second and third place awards in each grade division for each category above will be awarded.

PARADE OF LEADERS

PURPOSE

To recognize those young people selected for their leadership qualities to represent their respective groups. The parade is the kickoff for the Friday evening awards ceremony at convention. Two students will be chosen to participate in this Parade of Leaders. Students may be chosen by team leaders or peers. Students must carry either a poster, pennant or sign to identify their congregation. Please check the convention schedule for parade assembly time. Students selected to represent their home congregation should view this as a great honor. The names of the students chosen do not need to be turned in to the National Service Center.

PARADE OF WINNERS

(Reading the Bible)

This is a non-competitive event...one competes only with self.

PURPOSE

To encourage students and adults to read the Scriptures. There is no Convention participation for this award. This is a local, year-round event where participants read their Bibles.

EVENT PARTICIPATION

- A. Participation is open to all students and adults.
- B. Students attending the Convention must register as participants. Qualifying students and adults not attending the Convention must register to receive an award.

EVENT RULES AND GUIDELINES

- A. To qualify, the student or adult must read either the entire Old Testament or entire New Testament prior to the convention registration deadline.
- B. The reading may be from any standard translation not a paraphrase. Seek advice from your church leadership regarding various standard translations.
- C. Individuals may listen to audio tapes or CDs to qualify.
- D. All reading must be done within a 12 month period or less and must be done prior to convention registration deadline. Do not register for this event if the work is not completed by the registration deadline. **Group leaders are to electronically verify each participant of this event in the registration system.**
- E. A student or adult can qualify for more than one award in a calendar year by completely re-reading the (Old or New) Testament or reading the entire Bible prior to Convention registration deadline.

****Verification forms/lists do NOT have to be mailed to the National Service Center.****

AWARDS

Awards will be given to those who meet the requirements. If the recipient does not attend the Convention, the local team leader may pick up the award at Convention.

PEARLS

PURPOSE

To provide students with a deeper study into the Bible Bowl book selected for the convention year.

EVENT PARTICIPATION

Written Test

Students will participate in five divisions:

Grades 3-4 Grades 5-6 Grades 7-8
Grades 9-10 Grades 11-12

The annual Pearls Study Guide material may be ordered from the National Service Center.

EVENT RULES AND GUIDELINES

Written Test

1. Students will take the written test individually.
2. Questions will be based from a study guide that will be made available from the National Service Center each year. The study guides are excellent classroom material.
3. Local congregations will administer the multiple choice test in a controlled and monitored environment during the testing dates specified by the National Service Center. There will be a one-hour time limit for all written tests. Local congregations should mail the answer sheets back to the Lads to Leaders National PEARLS Coordinator for your respective convention location by the deadline specified.
4. For students that have problems reading, the questions and answer choices may be read to them by an adult. However, no student may take the test "open book."
5. There will be two different tests given – one for the students in grades 3-6 and one for students in grades 7-12. Please make sure that the correct test is given to the correct grades because the answers keys will be different.
6. Students will be compared to others in their same grade level. This is not a pass or fail grade.

JUDGING

A. Written Test

The written test will be individually scored.

- B. The test dates are published on the National Service Center website, please make sure you schedule the testing so that they are completed and mailed to the National Pearls Coordinator for your respective convention so that they are received by the published deadline.

AWARDS

The ten top scorers in each age division on the written test will be recognized.

PUPPET THEATER

PURPOSE

To train students to teach children Biblical principles using puppets. Participants learn valuable team-working skills in their preparation and presentation. Great opportunity for participants to gain self-confidence in public presentations.

EVENT PARTICIPATION

Performances will be held in the following divisions. The team must participate in the division of the oldest member. Students may participate on only one puppet team.

Grade 3	Grade 4	Grade 5	Grade 6	Grade 7
Grade 8	Grade 9	Grade 10	Grade 11	Grade 12

Students in grades K-2 may participate on third grade or older puppet teams.

EVENT RULES AND GUIDELINES

- A. A team may consist of no more than 12 members.
- B. Puppet shows must adhere to the announced Convention theme and teach a Biblical message. The message being taught is more important than the performance.
- C. No team is to use the name or use any sign that would identify its congregation.
- D. Each grade division will participate in a different room.
- E. Representatives from each congregation should report to the registration area on Friday morning to obtain a performance time for each team, if not already received by email, and to verify that the required number of judges will be present at the judges' meeting. NOTE: Special requests for performance times will be considered by the Puppet Theater Coordinator, but are not guaranteed. Please provide the reason for the request when submitted. Only requests received by the posted convention registration deadline will be considered. Times will be sent to the Puppet Theater coordinator for each group that provides an email address in the registration system. Otherwise, they will be sent to the Team Leader.
- F. Teams CANNOT practice on stages at the Convention. Team captains can inspect their performance room, but cannot alter the stage setup. Report any problems to the puppet coordinator.
- G. The puppet team must be at the performance room at their designated performance time. Failure to be at the room on time may result in disqualification.
- H. The timekeeper will announce teams to perform by letter designation at the time of performance.
- I. After announcement, each team will have a total of 12 minutes to set up, present puppet show, remove all equipment, and exit the room.
- J. The stage area must be left as it was found (i.e. four chairs in front area, walkboard in rear area, and curtains back in place). A penalty of two points will be deducted from each judge's sheet for failure to do so.
- K. The team captain or adult leader must state "we are clear" or "clear," and the timekeeper will stop the stopwatch.
- L. **The timekeeper will give an oral warning at the 10-minute mark of the performance –meaning there are only 2 minutes left without penalties.**
- M. The puppet show (actual performance) must be a minimum of five minutes. Groups will be penalized two points for one to 30 seconds under five minutes; four points for 31 to 60 seconds under; etc.
- N. Adult leaders may assist in set-up and take-down. However, all adults must clear the stage area during the performance.
- O. Tapes/CDs may be used for special effects. However, Lads & Leaderettes must use their voices for puppets. Prerecorded script dialogue will not be permitted. Instrumental music **MUST NOT** be used for "church" or "religious" songs. It is recommended that musical instruments not be used even for secular songs. However, groups that choose to have musical accompaniment for secular songs will not be penalized. Special effects must not overshadow the message.

- P. One narrator per puppet team may be used but must be in the same age division as the team. The narrator may stand to the side or front of the stage or may choose to be behind the curtain using a puppet.
- Q. All stage props **MUST** be within the dimensions of the stage or attached to the stage. No attachment should extend more than 12 inches beyond the frame of the stage, and must be attached to the frame at all times. No electrical power cords (extension cords) are allowed to extend from wall outlets to the stage/prop area.
- R. All special effects (lighting, sound, etc.) must be controlled by team members rather than adults. The lights in the performance rooms **CANNOT** be turned off during any part of a performance. This is because not all rooms have independent controls and the judges need to be able to see to make notes and score the performances.
- S. Public address systems will not be provided or allowed. CD players may be used but will not be provided. They must be battery-powered.
- T. Four standard chairs will be provided in the front stage area and a walkboard (measuring 2" x 10" x 8') in the back stage area. These items may be removed if a team does not wish to use them; however, they must be returned when the team is finished. Any adjustments, such as these, must be made during the 12-minute show time.
- U. **Any congregation having three or more participating teams must provide at the convention site a stage and walkboard built to the specifications outlined later in this section. Indicate in your group's online registration how many stages you are willing to bring to convention. PLEASE ENSURE THAT YOUR STAGES ARE BUILT TO THE SPECIFICATIONS IN THIS RULES BOOK. If possible, build an adjustable stage that can be used for either the younger or older teams.** The national puppet coordinator will be in contact with those congregations to make arrangements for setup at the convention site.
- V. A written script does **NOT** have to be turned in at the time of the performance.
- W. Puppeteering is not part of the worship service.
- X. The target audience for Puppet Theater is children.

JUDGING

- A. Judges must be knowledgeable of the rules for this event. Each congregation **MUST** supply at least one judge per team. Register the judges on the convention internet database. Judges should be selected from those who are not directly working with a puppet team because team (Red, Blue, Green, etc.) performances are simultaneous.
- B. Each room of participants will have a minimum of three judges. A separate timekeeper will be in the room when a sufficient number of judges are registered. Otherwise, one of the judges will also serve as the timekeeper.
 1. Judges may not score their own team.
 2. Judges must use the official score sheet provided.
- C. Score sheet terms explained:
 1. Creativity – Using original ideas, costumes, effects, teaching methods.
 2. Based on Convention Theme – Play must be based on the announced convention theme.
 3. Biblical Message – Does it teach a Biblical message?
 4. Animation – Does the movement of puppets' mouths match the dialogue? Do the puppets have good position? Can the puppets be seen or are they sinking too low? Are puppeteers hidden, or do you see tops of heads? Are the entrances and exits done smoothly? Do the puppets look natural?
 5. Sound quality – Are the puppeteers speaking loudly enough to be heard? Are the words clearly enunciated?
 6. Special effects – What is the quality of the props? Do the props and special effects enhance or detract from the play? Are the special effects excessive and take away from the Bible message?
 7. Teamwork – Was the set up and take down smooth? Was there excessive noise or activity behind the stage not relating to the play? Do puppets relate to each other during the script (looking at who is talking, etc.)?
 8. Overall Impression – Appeal, impression, Biblical message.
 9. Penalties – Each team will have a total of twelve minutes for set-up, show, and take-down. Groups will be penalized two points for one to 30 seconds over 12 minutes; four points for 31 to 60 seconds over; etc. The "message" or show must last at least five minutes. Groups will be penalized two points for

one to 30 seconds under five minutes; four points for 31 to 60 seconds under; etc. Self-identification will be penalized 20 points. Special effects that detract from the message will be penalized 10 points.

SUGGESTIONS

- A. Remember team effort. Teamwork is important – leaders must work together as a team.
- B. The Biblical message should be clear and not lost in the theatrics.
- C. Practice complete program, including set-up and take-down.
- D. Everyone has a job and must realize the importance of his/her responsibility.
- E. If more than one team is competing in different divisions, it would be advisable to have puppets for each team. Problems may result if two teams sharing the same equipment are scheduled at the same time. There is not a guarantee that special schedule requests can be honored.
- F. It is best not to make props exactly the width or height of the stage. Some stages may vary slightly. Make props with hangers large enough to go over a 1-1/2" pipe and thick curtain.

AWARDS

- A. Team awards will be presented to the first, second, and third place winners in each division.
- B. All participants on the winning teams will receive individual awards.

BASIC PARTS LIST FOR:

Puppet Stage

- 10 "T" connectors for 1 ½ inch PVC pipe
- 8 90° elbow joints for 1 ½ inch PVC pipe
- 8 10-foot long pieces of 1 ½ inch PVC pipe

Bases

- 6 10" x 10" x 1 ½" wood blocks
- 6 Galvanized floor flange for 1 ½" PVC pipe
- 24 1 inch #12 flathead screws for securing flanges to wood blocks
- 6 1 ½" PVC pipe-threaded coupling

Walk Board

- 1 10-foot long 2 x 10

Curtains

Dark material (must not be able to see through curtains) that is 60 inches wide by 20 yards long.

Cuts to be made to PVC pipes:

- Pipe #1 – Cut two pieces 49" long each, and one piece 17 ¾" long
 - Pipe #2 – Cut two pieces 49" long each, and one piece 17 ¾" long
 - Pipe #3 – Cut two pieces 43 ¾" long each, and two pieces 14 ½" long each
 - Pipe #4 – Cut one piece 106" long
 - Pipe #5 – Cut one piece 115 ½" long
 - Pipe #6 – Cut one piece 106" long
 - Pipe #7 – Cut one piece 85" long and one piece 30 ¾" long
 - Pipe #8 – Cut one piece 85" long and one piece 30 ¾" long
- From the scrap pieces, cut eight pieces that are 2 ¾" long each

Dimensions for 3rd and 4th Grade Puppet Stages

The cuts listed above and the instructions on the following pages are for stages for 5th grade and older teams. Stage height for 3rd and 4th grades is reduced by 12". Front tier will be 3' 6"; middle tier will be 5'; and back tier will be 6' 6". To account for this difference, if you intend to build a stage for the younger kids, make the following adjustments to the cuts: Pipe #1 and Pipe #2 – change 49" pieces to 37" pieces (2 front and 2 middle posts); Pipe

#7 and Pipe #8 – change 85" pieces to 73" pieces (2 back posts). All other cuts and instructions will be the same. The dimensions for the front curtains and the back, side curtains will be reduced by 12" each to 42" and 78", respectively. The middle and back tier curtains will be the same measurement for both size stages.

It is highly recommended that groups build adjustable stages that can be used for any age team. To do this, build a stage to the dimensions listed above for 3rd and 4th grade teams. Then purchase six (6) straight PVC couplers to join two pieces of 1 ½" PVC pipe. Since the length of the couplers may vary, we will not provide specific lengths for the additional pieces of PVC pipe needed to raise the stage to the height required for the older teams. Cut the pieces so that when inserted into the coupler and then added to the legs of the stage, the entire stage is raised by one foot to the height shown on the drawing that follows these instructions. It is recommended that screws are used at the coupler joints for added stability. For adjustable stages, the curtains should be made to the longer specifications. They can either be pinned up when the stage is shortened or left long.

Assembly Notes and Suggestions:

1. Use 1 ½" PVC pipe for stage.
2. Make sure that all cuts are square to ensure accurate dimensions. Either use a power miter saw or a miter box and hack saw.
3. Glue the joints where the 2 ¾" pieces were used to keep from losing the small pieces when stage is disassembled. It is recommended that the other joints not be glued so that stage can be easily disassembled for transporting. Screws or holes with pins at the joints will make the stage more sturdy during use.
4. After initial assembly, use a permanent marker to mark the location of each vertical post (front right; middle right; etc.). Also, to aid in re-assembly, number each side of the joints that are not glued so that they can be matched up easily.
5. Please note that the middle, vertical posts will not line up with the other two because of the offset from the 90° elbows.

Assembly Instructions:

- Attach the floor flanges to the center of the wood blocks. Screw the pipe-threaded couplings into the floor flanges to form the bases for each vertical post.
- Lay out the bases on the floor as shown in the diagram. Insert the 49" pieces (four totals) into each of the front and middle bases. On top of the front pipes, place "T" connectors with the long side parallel to the front. On the middle pipes, place "T" connectors vertically with the bottom of the "T" facing toward the front.
- Into the outside of each of the two front "T" connectors, insert a 2 ¾" piece of PVC. Onto those pieces, place a 90° elbow with the opening facing the back.
- Insert one of the 106" pieces into the inside openings of the front "T" connectors.
- Insert a 43 ¾" piece into the opening of the 90° elbow on the front corner and the "T" connector on the middle post. Repeat for other side.
- Insert a 14 ½" piece into the top of the "T" connector on the center post. On top of that piece, place a "T" connector vertically with the bottom opening of the "T" facing inside. Repeat for the other side.
- Insert the 115 ½" piece between the "T" connectors on top of the center posts.
- Insert 17 ¾" pieces into the top openings of the "T" connectors on top of the center posts. Place a "T" connector on top of each of these that is parallel to the sides.
- Insert the two 85" pieces into the back bases. Place a "T" connector on top of each of these with the long side parallel to the back.
- Insert the second 106" piece between the "T" connectors on top of the back posts.
- Into the outside of each of the two back "T" connectors, insert a 2 ¾" piece of PVC. Onto those pieces, place a 90° elbow with the opening facing the front.
- Insert a 30 ¾" piece into the back of the "T" on top of the middle post and into the opening on the 90° elbow. Repeat for other side.

- Into the front of the "T" on the top of the middle post, insert a 2 ¾" piece. Onto that, place a 90° elbow with the opening facing inside. Into the elbow, insert a 2 ¾" piece. Onto that, place another 90° elbow with the opening facing to the back. Repeat for the other side.

Walk Board Instructions:

- Cut an 8 foot length from the 10 foot board. From the remaining two feet, cut three pieces that are 6 ½" long each.
- Place the three pieces under the long board (one at each end, and one in the center) and secure with 3" wood screws.

Curtains:

Dimensions for the cuts to the material to make the curtains are as follows (these dimensions allow for a 5 inch casing to go around rails and hem at bottom and sides):

- Front curtain – 60 inches tall by 233 inches wide. It will wrap from the middle post on one side around the front to the middle post on the other side. It needs to be one solid piece, no gaps. You will need an opening in the casing at each corner where the "T" connector will connect to the front vertical posts. Leave a gap in the stitching rather than cutting the material.
- Middle curtain – 42 inches tall by 131 inches by wide.
Back curtain – 43 inches tall by 120 inches wide.
- Two back, side curtains – 96 inches tall by 47 inches wide. They need to go from the back vertical post past the center post and around the top, curved pieces. You will need an opening in the casing at the joint where the "T" connector will connect with the middle vertical post. Leave a gap in the stitching rather than cutting the material.

PUPPET STAGE DIAGRAM

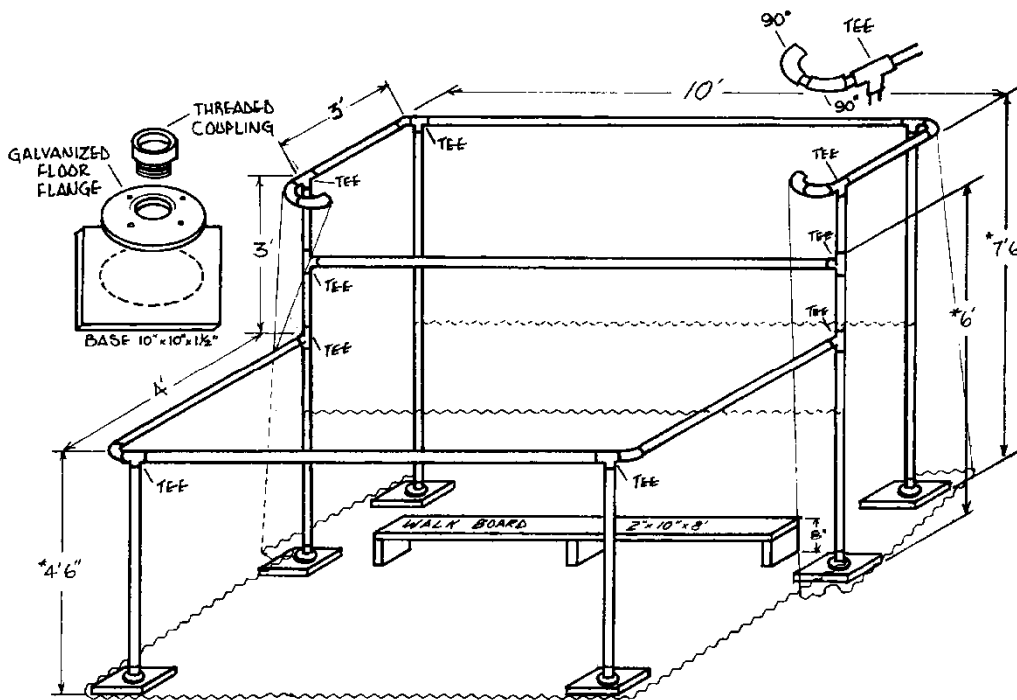

YEAR-ROUND (Advanced) PUPPETEERING

This is a non-competitive event... one competes only with self.

PURPOSE

An established team of puppeteers prepares and presents at least 10 presentations during the year as a teaching tool to reach out to the community. Examples include Vacation Bible School, children's training classes, hospitals, mission trips, schools, etc.

EVENT PARTICIPATION

Participation will be held in the following divisions. The team must participate in the division of its oldest member. Students may participate on one puppet team only.

Grade 3	Grade 4	Grade 5	Grade 6	Grade 7
Grade 8	Grade 9	Grade 10	Grade 11	Grade 12

EVENT RULES AND GUIDELINES

- A. A record of all performances by the puppet team must be kept. The majority of the performances must be by the same team members but exceptions and emergencies are understandable. Therefore, substitute team members are allowed.
- B. Performance at convention is not to be counted. Practice performances for coaches, team leaders and parents are not to be counted.
- C. Performances are to be counted from convention registration deadline to convention registration deadline, not January through December. Participants are to be registered for this event before the Convention registration deadline. **Group leaders are to electronically verify each participant of this event in the registration system.**
- D. Puppeteering is not part of the worship service.
- E. The target audience for Puppet Theater is children.

****Verification forms/lists do NOT have to be mailed to the National Service Center.****

AWARDS

- A. Team awards will be given for the number of presentations made from convention to convention.
 - Bronze 10-19 Presentations
 - Silver 20-29 Presentations
 - Gold 30 or more Presentations
- B. This is a team award to be shared by all participants.

INDIVIDUAL AND GROUP SCRAPBOOK

PURPOSE

To serve as record of the activities and growth of students and groups. To provide a tool for recording the special achievements in the lives of the individual students and to document events and activities of the local church.

EVENT PARTICIPATION

- A. Individual Divisions
- | | | |
|-------------|--------------|------------|
| Grades 3-4 | Grades 5-6 | Grades 7-8 |
| Grades 9-10 | Grades 11-12 | |
- B. Group Divisions – Scrapbooks entered by Lads to Leaders & Leaderettes groups, except those that have won first place ribbons in previous Conventions, are judged together. All groups that have won first place are judged in the Winners' Circle from then on.

EVENT RULES AND GUIDELINES

- A. Scrapbooks should pertain to Lads to Leader & Leaderettes activities as well as personal growth and development during the **current** year (from last Convention to present). First year scrapbooks may cover previous years.
- B. Individual scrapbooks must be the work of the student. While some adult guidance may be needed for Group scrapbooks, the creativity and products of the scrapbook must be the work of one student or the collaborative work of a group of students.
- C. All scrapbooks are to be **no smaller than 8 1/2 x 11 inches** and **no larger than 14 x 18 inches**.
- D. Scrapbooks should contain a table of contents, a preface or introduction, and a conclusion. The year covered in the scrapbook should be identified. Organization is an important aspect in judging the scrapbooks.
- E. The cover design of the scrapbook must have the following included in the cover design:
1. Name of the student or congregation.
 2. The name Lads to Leaders & Leaderettes or the "Flying L" logo.
 3. The actual Convention theme as published by Lads to Leaders & Leaderettes – no deviations or alternate interpretations.
- F. All scrapbooks must be registered through online registration. This is necessary to adequately prepare for the event and for verification of Winners' Circle recipients from previous years. **Scrapbooks cannot be submitted at the Convention unless they are registered.**
- G. Scrapbooks must be received at the Scrapbook Registration Desk on Friday at the scheduled time. A completed **Scrapbook Official Entry Sheet** must accompany the scrapbook.

JUDGING

- A. Groups must provide at least one judge per three registered scrapbooks. If less than three books are registered, a minimum of one judge must be provided.
- B. Judging will be completed prior to the Friday evening assembly. Scrapbooks should remain on display until 5:00 PM on Saturday. Groups are responsible for picking up their scrapbooks.
- C. Judges are reminded not to reveal the results before the awards ceremony.
- Criteria for Judging:
1. Cover Design (10 points): Does the book conform to the specified requirements for the cover?
 2. Table of Contents (10 points): Is a table of contents included in the book? Is it clear and concise? Does it help the reader understand the organization of the book?

3. Organization/Composition/Construction (20 points): Does the book follow a natural sequence representing the last year's work? If this is the first scrapbook compiled by the individual or group, does it follow a natural sequence in showing their history of involvement in the program? Are activities and other items easily understood? Is the book well-made or does it fall apart as it is viewed?
4. Appeal/Impression (15 points): Is the scrapbook appealing to the eye and easy to follow? Is it attractive? Too cluttered? This category includes layout, use of pictures, and the labeling of pictures.
5. Creativity (15 points): Is the scrapbook original and unique in the ways that ideas are presented?
6. Theme (15 points): Does the scrapbook reflect a theme throughout the book? The theme can be an idea such as kites, music, travel, etc. or the actual convention theme carried out through the entire book. The theme makes the scrapbook flow from the first page to the last page.
7. Conclusion, Summary and Future Expectations (15 points): Does the conclusion briefly summarize the student's or group's year in the program as well as reflect their vision for the future.
8. Judges are to assume that the work is that of the student. Judges are not to be in the role of judging capabilities of the student. Lads to Leaders & Leaderettes promotes the honor system.

D. Penalties

1. Scrapbooks received after the required deadline will be judged as late entries, and a penalty will be assessed. Students will be penalized five points for one to 15 minutes past the deadline; ten points for 16 to 30 minutes past the deadline; etc.
2. Scrapbooks that do not meet the size requirements as specified in the general rules will be penalized five points.

AWARDS

- A. First, second, and third place awards will be given in all divisions with three or more entries. **When the numbers in a category exceeds 12 in any one grade division, finalist awards will also be given.**
- B. Participants are not eligible to win multiple categories with the same entry.

WINNERS' CIRCLE SCRAPBOOK INDIVIDUAL AND GROUP

EVENT PARTICIPATION

A. Individual – First place winners in the Individual Scrapbook event from previous years.
Grades 4-6 Grades 7-9 Grade 10-12

B. Group – First place winners in the Group Scrapbook event from previous years.

EVENT RULES AND GUIDELINES

All rules for the regular Individual and Group scrapbook event apply.

AWARDS

First, second, and third place will be recognized with awards in both Individual and Group scrapbook. **When the numbers in a category exceeds 12 in any one grade division, finalist awards will also be given.**

SECOND LANGUAGE

PURPOSE

To promote and increase the ability of men and women to be able to communicate basic information and also to teach the gospel of Jesus Christ in a second language and/or sign language.

EVENT PARTICIPATION

- A. Participation is for Kindergarten through Adults. This is not a convention event. Participants demonstrate these skills at a local level.
- B. Participants may begin work at any time on this event.
- C. Participants are allowed to advance one award level per year. The Bronze award must first be obtained before completion of the Silver award, and completion of both Bronze and Silver is necessary to be eligible to complete the Gold level award. The Bronze and Silver level are preparation level awards. A participant may complete these awards by communicating the assigned tasks to any individual, not necessarily someone who does not speak English. The Gold level is an application level award. In order to be eligible for this award, the participant **MUST** complete the assigned tasks in communication with someone who does not speak English or uses sign language.
- D. Multiple awards may be earned in a convention year. For example, a person may complete the Bronze level in both sign language and Spanish, or both French and German. The participant must be registered for this event before the Convention registration deadline. **Group leaders are to electronically verify each participant of this event in the registration system.**

****Verification forms/lists do NOT have to be mailed to the National Service Center.****

EVENT RULES AND GUIDELINES

- A. **BRONZE LEVEL** (Preparation Level) The participant is able to clearly communicate both section one and section two of the following to another person or persons, using a language other than their own or by using sign language. As stated above, this communication can be given to any individual, and this individual can be someone who speaks English.

SECTION ONE

Learn to say the following phrases fluently in another language by memorization of the phrases:

Hello, my name is _____.

Jesus loves you.

What is your name?

Do you need help?

I am from _____.

Are you hurt?

Where is your home?

I love you.

Where is your father or mother?

The Bible is the Word of God.

SECTION TWO

Learn to say the following scriptures in another language fluently by memorization of the verses:

Genesis 1:1

Philippians 4:6-7

John 3:16

John 14:6

Acts 2:38

Matthew 28:18-20

Ecclesiastes 12:13

Acts 10:34-35

I Timothy 3:15

- B. **SILVER LEVEL** (Advanced Preparation Level) The participant is able to clearly communicate both section one and section two of the following to another person or persons, using a language other than their own or by using sign language. As stated above, this communication can be given to any individual, and this individual can be someone who speaks English.

SECTION ONE

Achieve the bronze level award during a previous convention year.

SECTION TWO

Learn to say the following scriptures in another language fluently by memorization of the verses for the purpose of teaching the gospel of Jesus Christ:

Romans 10:9-10

Acts 17:30-31

Mark 16:15-16

Romans 3:23

Acts 22:16

Romans 6:4-5

Hebrews 1:1-2

James 2:18-20

John 3:5

John 14:1-3

Ephesians 4:4-6

- C. **GOLD LEVEL** (Application Level) The participant is able to clearly communicate both section one and section two of the following to another person or persons who does not speak English, using a language other than their own or by using sign language. As stated above, this communication **MUST** be someone who does not speak English and is an application level award.

SECTION ONE

Achieve the silver level award during a previous convention year.

SECTION TWO

Complete two of the following:

1. Participate in a mission trip by using second language and/or sign language skills. A log of this communication should be kept and approved by local congregation representative.
2. Sign or interpret at a local church service, church event or Bible class at least six times in a period of one year. A log of completion should be kept and approved by local congregation representative.
3. Teach the gospel to someone using second language and/or sign language skills. A log of completion should be kept and approved by local congregation representative.
4. Teach a Bible story to children using second language and/or sign language skills at a VBS, Bible class or in a mission field setting at least six times. A log of completion should be kept and approved by local congregation representative.

EVALUATION

- A. A participant's progress shall be monitored by someone selected by the local church leadership as one demonstrating ability, experience and expertise in the chosen language or sign language.
- B. The local church leadership will evaluate and acknowledge when the participant has successfully completed the various awards, and the log sheets and verification forms should be kept in each person's records locally.

SONG LEADING

PURPOSE

To train young men to fulfill the role of song leaders in the church, since singing is a vital part of the worship service.

EVENT PARTICIPATION

- A. The song leading event will be held in the following grades:
Grade 3 Grade 4 Grade 5 Grade 6 Grade 7
Grade 8 Grade 9 Grade 10 Grade 11 Grade 12
- B. Each student must participate in the academic grade in which he is presently enrolled.
- C. Students in Kindergarten through 2nd grade and Bartimaeus participants may lead, but will not be judged.

EVENT RULES AND GUIDELINES

- A. Lads will be allowed to use a songbook of the leader's choice or song sheets. Be sure to bring copies of the words and music to aid in participation if you are not using a songbook. If using a songbook, bring extra copies to aid in audience participation. Unauthorized photocopying of music is an infringement of copyright and will not be allowed. Songs may be copied under a participant's Right to Copy Contract through his home congregation. The CCLI number **must be** on the copies – even those printed from the Paperless Hymnal program. To obtain a license, call CCLI at 1-800-234-2446 or visit their website at www.ccli.com. Copies may be taken up and reused. Leaders are responsible for providing their own books.
- B. If you bring extra song books for the audience you will not have to get copyright permission.
- C. **ALL** photocopies of songs used at convention **MUST** have either a CCLI number or the words PUBLIC DOMAIN (when applicable) written on them. If nothing is noted on the copies, the penalty for copyright infringement (-3 points) will be imposed. You can verify the copyright status of any song at www.ccli.com. It is highly recommended that groups get a CCLI license number so that it can be written on all copies. By doing this, you don't have to check the status of a song before making copies.
- D. Not less than two stanzas and not more than three stanzas shall be led.
- E. The name and number of the song should be announced so that all can hear.
- F. The song must be pitched properly and maintenance of pitch will be judged.
- G. Participants should project their voice to fit the room.
- H. Proper hand signals must be used.
- I. Proper transition from one stanza to the next will be judged.
- J. Projecting the thought and meaning of the song will be judged.
- K. Personal appearance is important. This includes not only appropriate dress, but also posture, poise, and neatness.
- L. Rules regarding identification of participants:
 - 1. Participants shall not be introduced by name of congregation.
 - 2. Participants will draw a number for the order in which they will lead. The number each participant draws shall be his identification. The judges should not know the participants' names, home congregations or even geographical origin. Any self-identification, including apparel, by the student shall be penalized three points.
- M. A Finalist is defined as a student who leads his song a second time during a second/final round. If a grade uses only one room, and does not break out into a second room, there will be **NO FINALISTS** for that grade. Only the top three students will be called by name to the stage during the awards ceremony. When two rooms are used for a grade, the top three students in each room will come together again to lead their song a second time in the second/final round. These students are **FINALISTS** and should proceed to the stage when finalists for that grade are called.

JUDGES' INSTRUCTIONS FOR SONG LEADING

- A. Song leading is to be judged on a 1-10 continuum with 10 points being the highest.
- B. Judges will rate each participant upon the following criteria:
 - 1. The proper announcing of the song number or title must be distinct where everyone can hear.
 - 2. The participant's neatness and appropriateness of dress, proper poise, and posture while leading song must be evident.
 - 3. The ability of the participant to start the song on the pitch for which the song was written.
 - 4. The ability of the participant to maintain the same pitch.
 - 5. The ability of the participant to project his voice in relation to the size of the room and size of the audience.
 - 6. The awareness and implementation of the proper tempo.
 - 7. The ability of the leader to maintain the established tempo throughout the song (not rushing or dragging).
 - 8. The ability of the leader to execute a smooth transition from one verse to another.
 - 9. The consistent and effective use of the hand signals.
 - 10. Control of the audience throughout the song.

JUDGING

- A. Each congregation should provide one male judge for each three participants. If less than three students participate, a minimum of one male judge should be provided.
- B. Every attempt shall be made to ensure fairness in evaluating the students.
- C. Although there are definite standards of good song leading practices, these are all matters of judgment as one attempts to score another's performance.
- D. The preliminary round shall have no more than 15 participants.
- E. No spectator may enter or leave the audience while a participant is leading a song.
- F. An interval of at least one minute shall be allowed between participants.
- G. The judges shall not be acquainted with any of the participants, if possible.
- H. The judges must use the official Scoring Sheets furnished.
- I. The judges shall be at different locations in the room. They should not be recognized or introduced until after the event is completed.
- J. Each judge shall render his final decision of all participants without consultation with other judges or any other person.
- K. Participants will draw a number for the order in which they will lead.
- L. The results of a judge's decision shall be kept confidential.
- M. Judges are asked not to give advice or attempt to coach the participants after the event. Please leave this to the students' own coaches. Even if a participant should ask for a list of strengths, weaknesses, etc., please avoid giving such. This is accomplished in the Advanced (Year Round) Song Leading where evaluations and suggestions are given to the participants.

AWARDS

First, second, and third place in each division will be awarded. Any participant who leads his song more than once will receive a finalist award. There will be only one round (no finalists) if only one participation room is used.

WINNERS' CIRCLE SONG LEADING

EVENT PARTICIPATION

A. All first place Song Leading event winners from all previous Lads to Leader & Leaderettes Conventions will participate with other first place winners in the following divisions, as long as there is a sufficient number of participants:

Grades 4-6

Grades 7-9

Grades 10-12

For convention locations with multiple color divisions, there may be a need to combine participants in some or all grade divisions in order to have a sufficient number for participation. See the final convention schedule for room assignments. If after 2-3 years in Winners' Circle, a student is not benefiting from the experience and is getting discouraged, he may return to regular Song Leading.

EVENT RULES AND GUIDELINES

- A. All Song Leading event rules apply to the Winners' Circle event.
- B. Participants will not participate in the regular Song Leading event.
- C. Grades 4-6 will lead the song of their choice. Grades 7-12 will lead one song of their choice **AND** lead one song from the list provided below. Participants will draw for song selection.

WINNERS' CIRCLE SONGS

- *A Wonderful Savior*
- *Count Your Blessings*
- *Faith is the Victory*
- *Heaven Came Down*
- *I Know That My Redeemer Lives*
- *I Must Tell Jesus*
- *I Will Sing the Wondrous Story*
- *Leaning On the Everlasting Arms*
- *Living By Faith*
- *Love Lifted Me*
- *I'll Be List'ning – Newly added for 2010 convention*
- *Mansion Over the Hilltop*
- *My Hope is Built On Nothing Less*
- *O Worship the King*
- *Standing On the Promises*
- *The Glory-Land Way*
- *'Tis So Sweet*
- *Victory In Jesus*
- *We Will Glorify the King of Kings*
- *We're Marching to Zion*
- *When The Roll Is Called*

AWARDS

First, second, and third place awards will be given in each division.

YEAR-ROUND (Advanced) SONG LEADING

PURPOSE

To prepare young men to be accomplished song leaders by encouraging them to lead songs at worship assemblies, Bible classes, devotional groups, or other appropriate audiences, such as civic clubs or schools.

EVENT PARTICIPATION

Grades 3-College (not to exceed 23 years of age) may participate.

EVENT RULES AND GUIDELINES

- A. Prepare not less than 12 different songs to lead before an audience. Students who participate more than once may not use prior songs led in this event, but must prepare 12 different songs. Lead these songs locally. There will be no convention participation in this event.
- B. Students may do an accelerated program or the program may be started in any month of the year. However, all work must be done within one consecutive 12-month period. The recommended procedure is for groups of songs to be spaced throughout the year with each group presented no less than one per month.
- C. Lead each of the 12 songs at least twice to different audiences. It is preferred that the first and last song leading times be spaced apart for improvement opportunity. The student may lead more songs, but a minimum of 12 songs led twice each is required to receive an award. Each song led before a different audience receives 1 point. Award levels are as follows:
 - 24-35 points receive a **Bronze** award.
 - 36-47 points receive a **Silver** award.
 - 48 or more points receive a **Gold** award.
- D. It is recommended that each song contain more than one verse. The student may lead as many verses as appropriate, but two verses (or twice through a song with one verse) is the absolute minimum per song.
- E. It is also recommended that students choose a variety of songs with different tempos, time signatures, starting pitches, and meanings (Prayer, Lord's Supper, Praise, Devotional, etc). The overall purpose of this event is to expand the students' repertoire of songs that can be comfortably led, and to have a greater understanding of the situations when certain types of songs should be led. An additional benefit for the students is for them to gain experience and understanding in working with others in planning songs for worship, devotionals, etc.

DOCUMENTATION

To qualify for the award, each student must maintain the following documentation. **A record must be maintained and may be kept at the home congregation. The participant must be registered for this event before the Convention registration deadline. Group leaders are to electronically verify each participant of this event in the registration system.** The National Service Center will use this to verify that the requirements are completed.

****Verification forms/lists do NOT have to be mailed to the National Service Center.****

- A. Students must keep a log for each song. The log must contain the following documentary information:
 - Date
 - Title of Song
 - Place (e.g., church name)
 - Type of audience (e.g., Bible class, devotional, worship service)
 - Full name, signature and phone number of adult witnessing (e.g., parent, youth director, team leader)

- B. A 200-300 word statement telling what the Advanced Song Leading Program has meant to the student.
- C. A judging sheet for at least two instances (first and last) of each song led.
- D. The official verification form from the Entry Forms and Log Sheets section of the Rules Book page of our website.

JUDGING

- A. Local Judging
 1. Judging should take place throughout the period of the time the student works in the Advanced Song Leading program; however, only the initial and final time each song is lead should be recorded. This is to show progress the student should gain throughout this program, from beginning to end. Judges should use the official Local Judges' Score Sheet. Ask someone in the audience (e.g., song leader for the congregation, youth director, minister, mentor) to judge the song from the audience and rate the student as good, excellent, or superior. This same judge should be used for both evaluations, first and last.
 2. Judges should be supplied with a score sheet that the student should retain for his records. Ratings are: Superior: 85-100; Excellent: 70-84; Good: 50-69. These ratings do not reflect the level of award that the student receives. Rather, they are to help show the student the areas in which he did well and the areas that need improvement.
 3. The two judge's sheets are required and must be included in the completed Advanced Song Leading file folder. One will be for the initial evaluation of the songs. The other will be for the final evaluation of the same songs. More than 12 songs can be judged, and the student can include more judges' sheets in the file.
- B. Convention Judging
 1. The Convention judge will review the necessary materials submitted for judging, including the Local Judges' sheets to look for improvement and the 200-300 word statement. He will make sure the copy of the log is at least 90% complete.

AWARDS

Awards will be given at Convention for the levels of Bronze, Silver and Gold.

CONGREGATION SUGGESTIONS

Have a qualified song leader at your congregation work with the students in this program throughout the year. Review their Local Judges' Score Sheets and make recommendations to help them improve.

LOCAL JUDGES' INSTRUCTIONS

- A. Be sure to completely fill out the student's name, group name, and participating grade. Please designate the type of audience(s) that the songs were lead to (e.g., worship service, devotional, nursing home service) and whether this particular sheet is the initial evaluation or the final evaluation. Also, please include your name on the sheet.
- B. Please work with the student to ensure their opportunity to lead the songs in a forum that allows optimal learning experience. The initial evaluation is for you to see how well they can lead at the beginning of this event. After reviewing the initial evaluation with the student and working with them to improve weak areas, then plan additional opportunities for the student to show improvement. Ideally, the final evaluation should be performed just prior to the convention deadline for these forms to give maximum time for student participation and improvement.
- C. Use a separate judging sheet for each time a song is lead. There is room to also record the song title if you find that helpful. The student will be keeping a log of these same songs, so it is not mandatory. Please ensure the sheet marked "Initial" is used for all first time evaluations of songs, and the sheet marked "Final" is used for all final evaluations of the songs.
- D. For each evaluation category, here is a quick statement of the intent behind the title:
Announce Number/Title - The proper announcing of the song number or title must be distinct where everyone can hear.

Appearance/Poise - The participant's neatness and appropriateness of dress, proper poise and posture while leading song must be evident.

Pitch Awareness - The ability of the participant to start the song on the pitch for which the song was written.

Maintenance of Pitch - The ability of the participant to maintain the same pitch.

Voice Projection - The ability of the participant to project his voice in relation to the size of the room and size of the audience.

Tempo Awareness - The awareness and implementation of the proper tempo.

Maintenance of Tempo - The ability of the leader to maintain the established tempo throughout the song (not rushing or dragging).

Transition of Next Verse - The ability of the leader to execute a smooth transition from one verse to another.

Hand Sign Use Effective - The consistent and effective use of the hand signals.

Leading the Audience - Control of the audience throughout the song.

- E. Since the rules state leading more than one verse, a penalty should be assessed for any song in which only one verse was led.
- F. Once you have completed your initial evaluation, plan some time to sit down with the student and go over the areas in which improvement can be achieved. Encourage practice at home and in sessions with small groups for enhancement of skills.

SONGS OF PRAISE

PURPOSE

To encourage girls to prepare themselves to lead women in song in ladies' classes, devotionals, retreats, etc. It is not the intention of Lads to Leaders & Leaderettes to promote or encourage women in leading singing for mixed groups. The integrity of this purpose must be maintained by the participants, parents, team leaders and elders of each congregation.

EVENT PARTICIPATION

- A. The Songs of Praise event will be held in the following grades:
Grade 3 Grade 4 Grade 5 Grade 6 Grade 7
Grade 8 Grade 9 Grade 10 Grade 11 Grade 12
- B. Each participant must participate in the academic grade in which she is presently enrolled.
- C. Students in Kindergarten through 2nd grade and Bartimaeus participants may lead, but will not be rated.

EVENT RULES AND GUIDELINES

- A. Leaderettes will be allowed to use any songbook of the leader's choice or song sheets. Please bring copies of the words and music of the song to aid in audience participation if not using a songbook. If using a songbook, bring extra copies of songbooks to aid in audience participation. Unauthorized photocopying of music is an infringement of copyright and will not be allowed. Songs may be copied under a participant's Right to Copy Contract through his home congregation. The CCLI number **must be** on the copies – even those printed from the Paperless Hymnal. To obtain a license, call CCLI at 1-800-234-2446 or visit their website at www.ccli.com. Copies may be taken up and reused. Leaderettes are responsible for providing their own books.
- B. If you bring extra song books for the audience you will not have to get copyright permission.
- C. **ALL** photocopies of songs used at convention **MUST** have either a CCLI number or the words PUBLIC DOMAIN (when applicable) written on them. If nothing is noted on the copies, the penalty for copyright infringement (-3 points) will be imposed. You can verify the copyright status of any song at www.ccli.com. It is highly recommended that groups get a CCLI license number so that it can be written on all copies. By doing this, you don't have to check the status of a song before making copies.
- D. Not less than two stanzas and not more than three stanzas shall be led.
- E. The name and number of the song should be announced so that all can hear.
- F. The song must be pitched and maintenance of pitch will be judged.
- G. Participants should project their voice to fit the room.
- H. Proper hand signals must be used.
- I. Proper transition from one stanza to the next will be judged.
- J. Projecting the thought and meaning of the song will be judged.
- K. Personal appearance is important. This includes not only appropriate dress, but also posture, poise, and neatness.
- L. Rules regarding identification of participants:
 - 1. Participants will not be introduced by name or congregation.
 - 2. Participants will draw a number for the order in which they will lead. The number each draws shall be her identification. The judges should not know the participants' names, home congregations or even geographical origin. Any self-identification by the participant, including apparel, shall be penalized three points.
- M. A Finalist is defined as a student who leads her song a second time during a second/final round. If a grade uses only one room, and does not break out into a second room, there will be **NO FINALISTS** for that grade. Only the top three students will be called by name to the stage during the awards ceremony. When two rooms are used for a grade, the top three students in each room will come together again to lead their song a second

time in the second/final round. These students are **FINALISTS** and should proceed to the stage when finalists for that grade are called.

N. No males will be allowed in the rooms where Leaderettes are participating in Songs of Praise.

JUDGING

- A. Each congregation should provide one female judge for each three participants. If less than three students participate, a minimum of one female judge should be provided.
- B. Every attempt shall be made to ensure fairness in evaluating the participants.
- C. Although there are definite standards of good song leading practices, these are all matters of judgment as one attempts to score another's performance.
- D. The preliminary round shall have no more than 15 participants.
- E. No spectator may enter or leave the audience while a participant is leading a song.
- F. An interval of at least a minute shall be allowed between participants.
- G. The judges shall not be acquainted with any of the participants, if possible.
- H. The judges must use the official Scoring Sheets furnished.
- I. The judges shall be at different locations in the room. They should not be recognized or introduced until after the event is completed.
- J. Each judge shall render her final decision of all participants without consultation with other judges or any other person.
- K. The result of a judge's decision shall be kept confidential.
- L. Judges are asked not to give advice or attempt to coach the participants after the event. Please leave this to the students' own coaches. Even if a student should ask for a list of strengths and weaknesses, etc., please avoid giving such. This is accomplished in the Advanced (Year-Round) Song Leading where evaluations and suggestions are given to the participants.

JUDGES' INSTRUCTIONS FOR SONGS OF PRAISE

- A. Song leading is to be judged on a 1-10 continuum with 10 points being the highest.
- B. Judges will rate each participant upon the following criteria:
 - 1. The proper announcing of the song number or title must be distinct where everyone can hear.
 - 2. The participant's neatness and appropriateness of dress, proper poise, and posture while leading song must be evident.
 - 3. The ability of the participant to start the song on the pitch for which the song was written.
 - 4. The ability of the participant to maintain the same pitch.
 - 5. The ability of the participant to project his voice in relation to the size of the room and size of the audience.
 - 6. The awareness and implementation of the proper tempo.
 - 7. The ability of the leader to maintain the established tempo throughout the song (not rushing or dragging).
 - 8. The ability of the leader to execute a smooth transition from one verse to another.
 - 9. The consistent and effective use of the hand signals.
 - 10. Control of the audience throughout the song.

AWARDS

First, second, and third place will be awarded in each division. Any participant who leads her song more than once will receive a finalist award. There will be only one round (no finalists) if only one participation room is used.

WINNERS' CIRCLE SONGS OF PRAISE

EVENT PARTICIPATION

All first place Songs of Praise event winners from all previous Lads to Leader & Leaderettes Conventions will participate with other first place winners in the following divisions, as long as there is a sufficient number of participants:

Grades 4-6

Grades 7-9

Grades 10-12

For convention locations with multiple color divisions, there may be a need to combine participants in some or all grade divisions in order to have a sufficient number for participation. See the final convention schedule for room assignments. If after 2-3 years in Winners' Circle, a student is not benefiting from the experience and is getting discouraged, she may return to regular Songs of Praise.

EVENT RULES AND GUIDELINES

- A. All Leaderettes Songs of Praise event rules apply to the Winners' Circle event.
- B. Participants will not participate in the regular Songs of Praise event.
- C. Grades 4-6 will lead the song of their choice. Grades 7-College will lead one song of their choice **AND** lead one song from the list of songs provided below. Participants will draw for song selection.
- D. No males will be allowed in the rooms where Leaderettes are participating in Winners' Circle Songs of Praise.

WINNERS' CIRCLE SONGS

- *Amazing Grace*
- *Heavenly Sunlight*
- *Jesus Is All The World To Me*
- *Mansions Over The Hilltop*
- *Sing And Be Happy*
- *Take The Name Of Jesus With You*
- *There Is Sunshine In My Soul Today*
- *There's A Fountain Free*
- *This Is My Father's World*
- *'Tis So Sweet To Trust In Jesus*
- *Trust And Obey*
- *Victory In Jesus*
- *When We All Get To Heaven*
- *Where He Leads, I'll Follow*
- *Yield Not To Temptation*
- *I'll Be List'ning – Newly added for 2010 convention*

AWARDS

First, second, and third place awards will be given in each division.

YEAR-ROUND (Advanced) SONGS OF PRAISE

PURPOSE

To prepare young women to be accomplished song leaders by encouraging them to lead songs at Ladies' Bible classes, ladies' devotional groups, Ladies' Day audiences, or other appropriate opportunities.

EVENT PARTICIPATION

Grades 3-College (not to exceed 23 years of age) may participate.

EVENT RULES AND GUIDELINES

- A. Prepare not less than 6 different songs to lead before an audience. Students who participate more than once may not use prior songs led in this event, but must prepare 6 different songs. Lead these songs locally. There will be no convention participation in this event.
- B. Students may do an accelerated program or the program may be started in any month of the year. However, all work must be done within one consecutive 12-month period. The recommended procedure is for groups of songs to be spaced throughout the year with each group presented no less than one per month.
- C. Lead each of the 6 songs at least twice to different audiences. It is preferred that the first and last song leading times be spaced apart for improvement opportunity. The student may lead more songs, but a minimum of 6 songs led twice each is required to receive an award. Each song led before a different audience receives 1 point. Award levels are as follows:
 - 12-17 points receive a **Bronze** award.
 - 18-23 points receive a **Silver** award.
 - 24 or more points receive a **Gold** award.
- D. It is recommended that each song contain more than one verse. The student may lead as many verses as appropriate, but two verses (or twice through a song with one verse) is the absolute minimum per song.
- E. It is also recommended that students choose a variety of songs with different tempos, time signatures, starting pitches, and meanings (Prayer, Lord's Supper, Praise, Devotional, etc). The overall purpose of this event is to expand the students' repertoire of songs that can be comfortably led, and to have a greater understanding of the situations when certain types of songs should be led. An additional benefit for the students is for them to gain experience and understanding in working with others in planning songs for classes, devotionals, etc.

DOCUMENTATION

To qualify for the award, each student must maintain the following documentation. **A record must be maintained and may be kept at the home congregation. The participant must be registered for this event before the Convention registration deadline. Group leaders are to electronically verify each participant of this event in the registration system.** The National Service Center will use this to verify that the requirements are completed.

****Verification forms/lists do NOT have to be mailed to the National Service Center.****

- A. Students must keep a log for each song. The log must contain the following documentary information:
 - Date
 - Title of Song
 - Place (e.g., church name)
 - Type of audience (e.g., Bible class, devotional, worship service)

Full name, signature, and phone number of adult witnessing
(e.g., parent, mentor)

- B. A 200-300 word statement telling what the Advanced Songs of Praise Program has meant to the student.
- C. A judging sheet for at least two instances (first and last) of each song led.
- D. The official verification form from the Entry Forms and Log Sheets section of the Rules Book page of our website.

JUDGING

- A. Local Judging
 - 1. Judging should take place throughout the period of the time the student works in the Advanced Songs of Praise program; however, only the initial and final time each song is lead should be recorded. This is to show progress the student should gain throughout this program, from beginning to end. Judges should use the official Local Judges' Score Sheet. Ask someone in the audience to judge the song from the audience and rate the student as good, excellent, or superior. This same judge should be used for both evaluations, first and last.
 - 2. Judges should be supplied with a score sheet that the students should retain for her records. Ratings are: Superior: 85-100; Excellent: 70-84; Good: 50-69. These ratings do not reflect the level of award that the student receives. Rather, they are to help show the student the areas in which she did well and the areas that need improvement.
 - 3. The two judge's sheets are required and must be included in the completed Advanced Songs of Praise file folder. One will be for the initial evaluation of the songs. The other will be for the final evaluation of the same songs. More than 6 songs can be judged, and the student can include more judges' sheets in the file.
- B. Convention Judging
 - 1. The Convention judge will review the necessary materials submitted for judging, including the Local Judges' sheets to look for improvement and the 200-300 word statement. He will make sure the copy of the log is at least 90% complete.

AWARDS

Awards will be given at Convention for the levels of Bronze, Silver and Gold.

LOCAL JUDGES' INSTRUCTIONS

- A. Be sure to completely fill out the student's name, group name, and participating grade. Please designate the type of audience(s) that the songs were lead to e.g., ladies class, ladies devotional, etc. and whether this particular sheet is the initial evaluation or the final evaluation. Also, please include your name on the sheet.
- B. Please work with the student to ensure their opportunity to lead the songs in a forum that allows optimal learning experience. The initial evaluation is for you to see how well they can lead at the beginning of this event. After reviewing the initial evaluation with the student and working with them to improve weak areas, then plan additional opportunities for the student to show improvement. Ideally, the final evaluation should be performed just prior to the convention deadline for these forms to give maximum time for student participation and improvement.
- C. Each judges' sheet can be used for the minimum 6 songs, even though it may span multiple song leading opportunities. There is room to also record the song title if you find that helpful. The student will be keeping a log of these same songs, so it is not mandatory. Please ensure the sheet marked "Initial" is used for all first time evaluations of songs, and the sheet marked "Final" is used for all final evaluations of the songs.
- D. For each evaluation category, here is a quick statement of the intent behind the title:
 - Announce Number/Title - The proper announcing of the song number or title must be distinct where everyone can hear.
 - Appearance/Poise - The participant's neatness and appropriateness of dress, proper poise and posture while leading song must be evident.

Pitch Awareness - The ability of the participant to start the song on the pitch for which the song was written.

Maintenance of Pitch - The ability of the participant to maintain the same pitch.

Voice Projection - The ability of the participant to project his voice in relation to the size of the room and size of the audience.

Tempo Awareness - The awareness and implementation of the proper tempo.

Maintenance of Tempo - The ability of the leader to maintain the established tempo throughout the song (not rushing or dragging).

Transition of Next Verse - The ability of the leader to execute a smooth transition from one verse to another.

Hand Sign Use Effective - The consistent and effective use of the hand signals.

Leading the Audience - Control of the audience throughout the song.

- E. Since the rules state leading more than one verse, a penalty should be assessed for any song in which only one verse was led.
- F. Once you have completed your initial evaluation, plan some time to sit down with the student and go over the areas in which improvement can be achieved. Encourage practice at home and in sessions with small groups for enhancement of skills.

SPEECH

PURPOSE

To provide a challenge to students to excel in public speaking and encourage high standards in speech content, organization and delivery. Public speaking is one of the greatest fears among Americans. It is proven that if a person learns to speak in public before they learn to fear it, then they will carry the talent with them for the rest of their life. Public speaking is a talent that will propel all professions and walks of life. Through participation in this event, students will learn to demonstrate the simple elegance of persuasive speech without the aid of modern technologies.

EVENT PARTICIPATION

- A. The Speech event will be held on a grade-to-grade basis from grades 3-12. Kindergarten through second grade students are given the opportunity to speak, although they will not be rated.
- B. Each participant must participate in the academic grade in which he/she is currently enrolled.

EVENT RULES AND GUIDELINES

- A. The speech shall be related to the Convention theme announced each year in the Convention Registration Packet. The speech does not have to specifically quote the theme.
- B. Participants may receive help in the preparation of their speech. Since one of the goals of participating in Speech is to learn how to research and write speeches, the amount of adult help should decrease as the student gets older. Review of the speech and suggestions by parents or mentors are parts of the process, but the students should do progressively more work on the speeches as they grow through the program.
- C. Time Limits and Penalties
 - 1. **Speeches will be three to five minutes in length for grades 3-6. Speeches shall be four and one-half to six minutes in length for grades 7-12.**
 - 2. Participants going over or under the time limit shall not be cautioned, but will be penalized two points for one to 30 seconds over or under; four points for 31 to 60 seconds over or under; etc.
 - 3. Students reading entirely from a script will be penalized three points.
- D. Identification of Participants
 - 1. Participants shall not be introduced by name or by congregation.
 - 2. Each participant will draw a letter for the position in which he or she will speak. The letter drawn shall be his or her identification. The participant's name, home congregation and even geographical origins should not be known to the judges. Any self-identification by the participants, including apparel, shall be penalized three points.
- E. A Finalist is defined as a student who gives his/her speech a second time during a second/final round. If a grade uses only one room, and does not break out into a second room, there will be **NO FINALISTS** for that grade. Only the top three students will be called by name to the stage during the awards ceremony. When two rooms are used for a grade, the top three students in each room will come together again to give their speeches a second time in the second/final round. These students are **FINALISTS** and should proceed to the stage when finalists for that grade are called.
- F. Use of modern technologies, such as, but not limited to, computers, projectors, CD players, etc. will not be allowed in the Lads and Leaderettes Speech events.
- G. A written copy of the speech does **NOT** have to be turned in at the time the speech is presented.
- H. No males will be allowed in the rooms where Leaderettes are participating in Speech.

JUDGING

- A. Judges should be familiar with all of the event rules.
- B. Each group must provide one judge for every three participants. (If less than three speakers, a minimum of one judge must be provided.) Please register your judges along with your participants. Please make sure to

register the appropriate number of female judges for the number of Leaderettes registered for speech, and the appropriate number of males for the number of Lads registered for speech.

- C. Every attempt shall be made to ensure fairness in evaluating the event.
- D. Although there are definite standards of good oratory and clear principles regarding content, organization, and delivery, these are all matters of value judgment as one attempts to score another's performance.
- E. Other Guidelines
 - 1. The primary round shall not have more than 12 participants ("A" – "L") per room.
 - 2. No spectator may enter or leave the audience while a participant is speaking. The audience should be alerted to this rule before the event begins.
 - 3. An interval of at least one minute shall be allowed between participants.
 - 4. The judges shall not be acquainted with any of the participants, if possible.
 - 5. The judges must use the Official Score Sheets furnished.
 - 6. The judges shall be at different locations in the room. They should not be recognized or introduced until after the event is completed.
 - 7. Each judge shall render his final decision on all participants without consultation with other judges or any other person.
 - 8. The results of the judges' decisions shall be kept confidential.
 - 9. Judges are asked not to give advice or attempt to coach the participants after the event. Please leave this to the students' own coaches. Even if a participant should ask for a list of strengths or weaknesses, etc., please avoid giving such.
 - 10. Applause is in order after each speaker has finished his or her speech. The applause simply says, "We appreciate you and the good efforts you have put forth."
 - 11. Lads and Leaderettes speech events are held separately. No males will be allowed as spectators in the Leaderettes Speech event at convention. This is to avoid misunderstandings. Girls are preparing themselves to teach ladies' classes and young children.

JUDGES' INSTRUCTIONS FOR SPEECH AND WINNERS' CIRCLE SPEECH

Participants may receive help in the preparation of their speech. The speech, Convention theme, and the material should receive equitable point value. The scoring has been divided into four phases.

The general intent of each phase is as follows:

PERSONAL QUALITIES – 20 POINTS

- A. Poise - Does the speaker have command of self and of the materials? Is the speaker under control?
- B. Personality – Does the speaker appear prideful or haughty? Humble? Is the tone warm and friendly?
- C. Appearance – Is dress appropriate? Is the speaker neat, clean, and well-groomed?
- D. Attitude – Does the speaker act like he or she desires to be in the event, or is made to participate; command the respect of the audience; or speak "to" people or "at" people? Caution: Don't judge on the externals alone. Be careful with response based on theatrics or emotion alone.

MATERIAL ORGANIZATION – 30 POINTS

- A. Biblical Truths – Is the speech scripturally sound? Are scriptures used or referenced?
- B. Adherence to Theme – Does the content of the speech relate to the Convention theme? (The actual theme phrase itself does not have to be used.) Or does the speaker use the theme phrase occasionally, while the speech has no relation to the theme subject?
- C. Value – Is the content a relevant message? Is the content appropriate to the speaker's age level?
- D. Logic – Does the speech present a rational thought process, sequential order to the speech?

DELIVERY AND PRESENTATION – 30 POINTS

- A. Voice – Does the speaker project well? Is the speaker's volume too high or too low?
- B. Enunciation – Are the speaker's words clear? Does the speaker avoid colloquial slurs? (thang vs. thing) Does the speaker emphasize proper syllables? Are d's, t's n's and ing's left off the end of words?

- C. Pronunciation – Are the speaker’s words distinct? Does the speaker observe the rules of proper grammar? Does he or she pause for commas, stop at periods, etc?
- D. Sincerity – Does the speaker feel his or her message? Is the speech personally owned? Is the speech appropriate to the age level? Does the speaker maintain eye contact with the audience?

OVERALL EFFECTIVENESS – 20 POINTS

- A. Appeal – Has the speaker communicated in such a way as to create understanding for his or her subject? Does the conclusion cause the audience to desire to own the message?
- B. Impression – Does the speaker accomplish his or her purpose? Does the content of the message fit the presentation? (Speaker’s personality, gestures, delivery, etc.)
- C. Effect – Did the speaker’s message and presentation move the audience to action? Did the audience form a conclusion, opinion, etc. based on the speaker’s message and presentation?

AWARDS

- A. While only three students in each grade will place, all of the finalists from the preliminary round will receive awards.
- B. First, second, and third place awards will be given for each grade division of participation for both Lads and Leaderettes. Any participant who is asked to give his/her speech more than once will receive a finalist award. There will be only one round (no finalists) if only one participation room is assigned and/or used.

LADS AND LEADERETTES WINNERS' CIRCLE SPEECH

EVENT PARTICIPATION

- A. Grades 4-12 are involved in the Winners' Circle Speech event.
- B. All first place speech winners from all previous Lads to Leaders & Leaderettes Conventions will participate with other first place winners in the following divisions:
Grades 4-6 Grades 7-9 Grades 10-12
- C. Winners' Circle participants will not participate in the regular speech event.
- D. If after 2-3 years in Winners' Circle, a student is not benefiting from the experience and is getting discouraged, he or she may return to regular Speech.

EVENT RULES AND GUIDELINES

All Official Rules for Lads and Leaderettes Speech will apply in full to this event.

AWARDS

- A. First, second, and third place awards will be given in each Lads and Leaderettes division.
- B. Winners' Circle events may or may not run simultaneously with the regular Speech event. **Check the convention schedule for specific information.**
- C. For convention locations with multiple color divisions, there may be a need to combine participants in some or all grade divisions in order to have a sufficient number for participation. See the final convention schedule for room assignments.
- D. No males will be allowed in the rooms where Leaderettes are participating in Winners' Circle Speech.

YEAR-ROUND (Advanced) SPEECH

This is a non-competitive event... one competes only with self.

PURPOSE

To promote year-round, local public speaking. To prepare students to be accomplished speakers and Bible class teachers by requiring them to deliver speeches to worship assemblies, Bible classes, devotional groups, or other appropriate audiences, such as civic clubs, ladies' day, lectureships, schools and etc.

EVENT PARTICIPATION

Grades 3-College (not to exceed 23 years of age) may participate.

EVENT RULES AND GUIDELINES

- A. Research and prepare not less than **6** different speeches on **6** different subjects for presentation. Students who participate more than one year may not use their prior speeches given in this event in previous years, but must prepare six new speeches. Present these messages locally. There will be no Convention participation in this event. This is a year-round event. Local record keeping is essential. Participants must be registered before the Convention registration deadline. **Group leaders are to electronically verify each participant of this event in the registration system.**
****Verification forms/lists do NOT have to be mailed to the National Service Center.****
- B. Speeches **do not** have to be the student's original work. Students may use speeches from ministers, speech books, etc. Proper credit should be given. Also older participants should do more research and preparation. Speeches must be at least 3 minutes minimum. However, the length of the speech may be determined by what is appropriate for the audience. (Ex. A sermon might be 15 to 30 minutes long.)
- C. Students may do an accelerated program or the program may be started in any month of the year. However, all work must be done within one consecutive 12-month period. The recommended procedure is for speeches to be spaced throughout the year with each presented not less than one per month.
- D. Make at least one presentation of each of the 6 speeches. Minimum of 12 presentations is required. The student may give several presentations of the same speech, but a minimum of one presentation of each of the six speeches is required to receive an award.

Award levels are as follows:

- Bronze** 12-17 total presentations of the 6 speeches
- Silver** 18-23 total presentations of the 6 speeches
- Gold** 24 or more total presentations of the 6 speeches

The Bronze level requires at least one presentation of each speech. The Silver level requires at least two presentations of each speech. The Gold level requires at least three presentations of each speech.

YEAR-ROUND (ADVANCED) SPEECH FILE FOLDER

- A. To qualify for the award, students must prepare two secure, expandable file folders. One file folder is for the student to keep. **The student must give the second one to the group leader or the designated person (mentor) who will maintain a file of Lads to Leaders and Leaderettes speeches at the church building or another safe site. These files can be used to verify**

speeches given and to serve as resource material for future speakers. You will be asked to verify that these requirements have been met.

- B. Each speech is to be filed in a separate folder (not less than 6 folders) which includes copies of all resources cited in the speech (i.e., list of scriptures, magazine or newspaper articles, electronic resources, etc.), and a typewritten copy of the speech itself. Each speech should be well prepared by being grammatically correct and without spelling errors.
- C. These two file folders are also to contain the following documentary information:
 - 1. The student must log each speech. The log must include:
 - a. Date of presentation
 - b. Title of speech
 - c. Place /Type of Presentation (Church, Bible class, devotional, etc.)
 - 2. The evaluation sheets for each speech: 4 minimum for Bronze, 6 minimum for Silver, 8 minimum for Gold (see Requirements).
 - 3. A one page statement telling what the Advanced Speech Program has meant to the student.
 - 4. The official Advanced (Year-Round) Speech Log located in the Entry Forms and Log Sheets section of the Rules Book page of our website.

EVALUATIONS/JUDGING

A. Local Evaluations

- 1. Evaluations/judging should take place throughout the period of the time the student works in this Advanced Speech program (beginning, middle, and near the end). This is to show the progress the student should gain throughout this program. Evaluators/Judges should use the official Local Evaluation Score Sheet. Ask two people (not parents) to evaluate the speech from the audience and to rate the speaker as good, excellent or superior.
- 2. Evaluators/Judges should be supplied with a score sheet that the student should retain for his records. Ratings are: Superior: 85-100; Excellent: 70-84; Good: 50-69. These ratings do not affect the level of award that the student receives. Rather, they are to help show the student the areas in which he/she did well and the areas that need improvement.
- 3. A minimum of two evaluation sheets for a minimum of two speeches (4 Total) are required for Bronze. Evaluators should not be a parent but preferably a church leader/their spouse. More presentations can be evaluated and the student can include more judges' sheets in the file. These sheets must include the date of evaluation, the speech, audience, and be signed by the evaluator.

B. National Service Center Verification

- 1. The Advanced Speech Committee will review the necessary materials submitted.
- 2. Items to be sent:
 - a. Speech Log
 - b. Evaluation Forms - 4 minimum for Bronze, 6 minimum for Silver, 8 minimum for Gold.
 - c. A one-page statement telling what the Advanced Speech Program has meant to the student.
 - d. Leader signed verification form.

AWARDS

Awards will be given at Convention for the levels of Bronze, Silver and Gold.

CONGREGATION SUGGESTIONS

- A. Maintain a file cabinet at the church building (or electronic storage) with Lads to Leaders and Leaderettes Speeches. (A GREAT RESOURCE!)
- B. Publish the Lads' or Leaderettes' activities in the bulletin throughout the year, such as who spoke where and when.
- C. Submit a newspaper-worthy picture and story about their accomplishments to the local newspaper.

- D. Send a picture and a notation of these achievements to the Lads to Leaders National Service Center for use in our newsletters and other publications. Include information about where they spoke, the date and especially their topic.

SUGGESTED TOPICS

A. Lessons from annual PEARLS study books; GIFTS; GUARD or JUNIOR LEADER.

B. Lessons from the *Lads to Leaders & Leaderettes Manual*

Acrostic Lessons

Great Leaders

The Leader Who Excelled the Most

What the Word of God is Like

God Oversees the Nations

Freedom to Possess or Exercise

God's Supreme Compliment to the World

Questionnaire on Teen Marriage

"The Most Important Woman in the World"

"The Temptation to Disobey Mother"

"A Good Listener Does These Things"

Trees Talk Purpose

Moonstruck

C. Resources from the *Lads to Leaders & Leaderettes Manual*

Leader Pledges

Personal File

Guiding Students to Successful Speaking

Goal Setting

"Learning Bible Reference Books"

Set up and keep expanding a personal file

Break a record

Study Speech Improvement Steps

Speaking Trip

Microphone Use Guidelines

Biblical Resource Information – Part VII

Local Evaluators/Judges' Instructions for Advanced Speech

1. Personal Qualities

25 points

(Poise, Personality, Appearance, Attitude)

In this category consider the speaker's appearance and personal qualities. Clothing should be clean, modest, tasteful and appropriate for the audience. Proper hygiene should be considered along with poise, personality and the comfort zone of the speaker.

2. Material/Organization Quality

25 points

(Value, Logic and Biblical Truth and Scriptures Quoted)

In this category, only the material and its organization presented by the student should be judged. One should consider the importance of adherence to the subject, and the logical and coherent development of the subject, which brings about a successful, logical, and adequate conclusion. Figures of speech, similes, metaphors, colorful choice of words and zestful, descriptive phrases are important qualities. Scriptural accuracy and adherence to Biblical truths are critical to consider in this section.

3. **Delivery & Presentation**

20 points

(Voice, Enunciation, Pronunciation, Gestures, Sincerity, Emphasis)

Delivery and presentation should be evaluated upon several factors. Voice quality should be recognized in tone, pitch, and volume. Delivery should be continuous, without hesitation or halting, unless it is for emphasis sake. Enunciation and pronunciation are very important. Gestures should be noted for frequency, nature, and effectiveness. Movement and gestures should not be awkward. Sincerity and enthusiasm are important qualities. The desire to be convincing should be obvious. Emphasis should be well-placed and dynamic, but not over done.

4. **Overall Effectiveness**

20 points

(Appeal, Impression, Effect, Did It Make Sense?)

In this category, the overall impression created by the speaker and the speech should be rated. The overall impression of a specific effect is a result of many factors, some of which are indefinable and inexpressible and cannot be individually scored. Yet, the final impression persists and is most important. In this phase of scoring, this general overall impression is given actual point value. Was the speech effective? Did it hit the target?

5. **Audience**

10 points

(Appeal, Impression, Effect, Appropriateness for the Audience, Held the Audiences' Attention)

It is important for students to learn what speeches to give to what audiences. In this category, the evaluators should evaluate the appropriateness of the speech topic for the audience present (ex., civic club vs. Bible class).

Teaching Event: About My Father's Business – Teach to Teach

This is a non-competitive event... one competes only with self.

PURPOSE

To emphasize the importance of training teachers for Bible classes and encourage students and adults to study and become better prepared to teach God's Word.

EVENT PARTICIPATION

Grades 7-12 and adults are eligible. Upon approval of the eldership or leadership of the local congregation, participants complete requirements on an individual level. The Lads to Leaders and Leaderettes organization does not promote students or adults participating in a Bible class in any way contrary to God's Word. Decisions about who is eligible to teach are a decision of the local eldership/leadership.

A. Level I – Student Teacher

Participants gain experience in the Bible classroom by completing the stated requirements. Participants can complete only one level per year.

B. Level II – Apprentice Teacher

Only those who have achieved the Student Teacher Level in a prior year may participate in the Apprentice Teacher Level. Participants use developed skills to teach others while improving the basic skills learned as a Student Teacher.

C. Level III – Master Teacher

Only those who have achieved the Student Teacher Level and Apprentice Teacher Level in prior years may participate in the Master Teacher Level.

OVERVIEW

While several participants may be completing requirements at the same time, the program is designed for individual completion. Participants are to complete their requirements individually (no team teaching to complete requirements; no teams creating lesson plans or teaching aids).

Training teachers to present God's Word has been a challenge to many congregations. Each level of this event becomes more challenging. This is by design so that when a student or adult becomes a Master Teacher, he/she will have developed into an excellent Bible class teacher of the Word of God.

Participants will keep a record (portfolio) of their work and update it as each level is completed. This record will be used at the end of the Master Teacher level and presented to the congregation's resource room or teacher work area. This is further explained on the Master Teacher event participation page. Participants must be registered before the Convention registration deadline. **Group leaders are to electronically verify each participant of this event on the registration system.**

EVENT RULES AND GUIDELINES

A. LEVEL I - STUDENT TEACHER

At this level, participants are introduced to the principles of teaching. Emphasis is on learning about teaching and observing good teachers in action.

Requirements:

1. Students and adults should complete one of the following options:

- Option One - The elders/leadership should appoint a mentor teacher to oversee and teach participants using the "Word to the Teacher" section of the Junior Leader Teacher's Edition book, which can be obtained from the National Service Center.
- Option Two - Use appropriate teacher training material developed by the congregation.

Upon completion of either option one or two, the participant should have begun to develop knowledge of basic teaching skills.

2. Observe a mentor teacher at two different class levels for six weeks each (total of twelve weeks of observation) from the following options: kindergarten, elementary, middle or high school. The observations do not have to be successive, but it would be good to have at least six weeks in one quarter and six weeks in another quarter. The eldership is responsible for deciding an appropriate class for students and adults to observe.
3. During one of the class sessions, tell or read the Bible story for the selected lesson under the guidance of the mentor teacher.
4. During one of the class sessions, help the class with a planned craft or activity for the selected lesson, or if the class is middle or high school, create a visual aid or lesson activity sheet to go along with one lesson under the guidance of the mentor teacher. Keep a copy of the craft, activity or lesson activity sheet in the portfolio.
5. Complete one of the following:
 - Option One - Observe and assist someone creating and putting up a bulletin board display. Report to the mentor teacher what has been learned about creating bulletin boards.
 - Option Two - Observe and assist someone painting and/or decorating a classroom for kindergarten, elementary, middle or high school. Report to the mentor teacher what has been learned about classroom decorating.
6. After the twelve weeks of observation has been completed, write a one-page summary of the observations. Discuss what has been learned about teaching, keeping the interest of the students and how to apply this to the participant's own teaching style. Submit a copy of the summary to the group leader and the eldership. Keep a copy in the portfolio.
7. Take pictures of the bulletin board and/or classroom decorations to be used in the portfolio for the Master Teacher level.

B. LEVEL II - APPRENTICE TEACHER

At this level, participants learn to write a simple lesson plan, make teaching aids and actually teach Bible class.

Requirements:

1. Must have completed the Student Teacher level in a prior year.
2. Observe a mentor teacher at two different class levels for six weeks each (total of twelve weeks of observation) from the following options: kindergarten, elementary, middle or high school. The observations do not have to be successive, but it would be good to have at least six weeks in one quarter and six weeks in another quarter. The eldership/leadership is responsible for deciding an appropriate class for students and adults to observe.
3. After the twelve weeks of observation, choose kindergarten, elementary, middle or high school and write two lesson plans using the outline given at the end of this section or a lesson plan approved by the elders/leadership of the congregation. The participant can be assisted with the lesson plan by his/her mentor teacher. After completing the lesson plans, the participant should teach them during two separate class periods to a group of students under the supervision of a skilled mentor teacher. The eldership/leadership must be notified that the participant wishes to teach the class using the developed lesson plans and must give approval before participant teaches the lessons to a Bible class. Keep a copy of the lesson plan in the portfolio.
4. Develop three teaching aids for teaching children. Ideas can be taken from Lads materials such as: Junior Leader Teacher's Edition, GIFTS, GUARD and Pearls. Participants may also find ideas from bookstores, the internet, resource centers, magazines and from mentor teachers.
5. In one class session, help the class with a craft or activity, OR if observing middle or high school, bring an object or visual aid and teach a five minute Bible lesson to the class. Keep a copy of the work for the portfolio.
6. With the help of the mentor teacher, create a bulletin board and put it up for display completely on their own, OR with the help of the mentor teacher, design and put together a classroom decoration on their own. Keep a copy of the material for the portfolio.
7. Take pictures of the classroom and bulletin boards to be used for the portfolio for the Master Teacher level.

C. LEVEL III - MASTER TEACHER

At this level, participants will be progressing in their teaching skills. They will develop a file of lessons and co-teach one quarter in a Bible class session, either six or seven lessons with the mentor teacher observing.

Requirements:

1. Students and adults must have completed the Student Teacher and the Apprentice Teacher levels before participating in this level.
2. Write two lessons using the lesson plan outline provided at the end of this section, or if the congregation already has a set curriculum, then write two lesson plans following the guidelines of the curriculum used by the congregation. Keep a copy of the lesson plans for the portfolio.
3. Co-teach with a mentor teacher for one quarter in one of the following classes: kindergarten, elementary, middle or high school, rotating weeks, so that the participant teaches at least six weeks. Participants may use the following options:
 - Option One: The current curriculum of the congregation.
 - Option Two: Materials from Lads to Leaders & Leaderettes such as: Junior Leader Teacher's Edition, GIFTS, GUARD or Pearls
 - Option Three: If approved by the eldership/leadership, teach classes using the four lesson plans previously prepared by the participant.
4. Continue to keep a file system for future use which includes a file for the four lesson plans developed during the Apprentice Teacher level and the Master Teacher level. Each file should contain all materials necessary for teaching each lesson including aids, activities, and handouts and may also include a CD copy. If materials are oversized and cannot be stored in a file, an explanation of the activity and location of materials should be included in the file.
5. Develop three teaching aids for the classroom in addition to the lessons. A good idea for these aids might be items that can be repeatedly used (example: a game for which review questions can be changed, an activity to teach ongoing memory work like Bible books, etc.). These should be added to the file system.
6. Complete the Master Teacher Portfolio. Include pictures of the teaching activities, created bulletin boards, decorated classrooms, crafts and lesson plans that have created. Include the summary of the first classroom observations and write a one page summary of the final co-teaching experience. This portfolio may be in the form of a scrapbook or a notebook. Submit the Portfolio to the mentor teacher and eldership for approval.
7. Participants may participate in the Master Teacher level yearly by completing all the requirements during that convention year, adding to their filing systems and their teaching experiences. Materials from previous years cannot be used if participant continues to participate yearly in Master Teacher level.

Completion Guidelines

- A. All required work should be completed prior to the convention registration deadline.
- B. All materials will be turned in to the mentor teacher and evaluated on the local level. However, participants are required to complete all the listed requirements in order to be listed as recipients of the awards. Group leaders **MUST** verify that all requirements have been completed prior to the convention registration deadline.

GROUP LEADERS: Make sure that all participants have been registered and verified for the award. Do not send participants' work (essays, files, etc) to the National Service Center. Participants will be listed in the convention program.

AWARDS

Qualified participants will be recognized at convention. All materials will be evaluated on the local level.

Lesson Plan Outline

1. Before the class begins—welcome the students; be prepared with songs and short fun activities, etc.
2. Opening—prayer, scripture, song, poem, story, etc.
3. Lesson—share story and visuals.
4. Activity—games, role play and dress up, etc.
5. Closing—repeat short point from lesson that you want them to remember and any announcements, assignments and take home papers.